

## PRICE LIST 2017

1. PROFESSIONAL KITCHEN WORKTABLES
2. OTHER TABLES AND STANDS
3. DISHWASHING EQUIPMENT
4. SHELVES AND CUPBOARDS
5. TROLLEYS
6. EXHAUST HOODS
- 7. BAR EQUIPMENT**
8. SERVING LINE EQUIPMENT
9. COOLING COUNTERS AND HEATED EQUIPMENT
10. MODULAR TABLES

**YOUR RELIABLE PARTNER**

*Novameta is the largest and most advanced manufacturer of stainless steel commercial kitchen equipment in Baltic and Scandinavian countries. Extensive 16-year experience, attention to details along with an innovative mindset are the key factors which have enabled **Novameta** to establish trust in 18 markets throughout Europe.*

*A wide range of hot, cold and neutral standard equipment, precisely engineered and crafted non-standard products combined with a short, typically 2-4 week lead time is what makes us stand out of the crowd. What is more, our experienced team is all set to provide professional support and technical advice, enabling our clients to turn their ideas to tailor made turnkey solutions.*

*All of our products are marketed through a professional network of distributors throughout Europe. We are proud to provide an all-round assistance to our dealers, helping them to excel in the things they do best - planning, taking care of supply, installation and service to fulfil the needs of catering, bakery and retail industries.*

*Our main objectives are to maintain solid positions in Europe through sustaining partnership relationships with our clients, whilst at the same time expanding into new markets worldwide. Experienced and ambitious sales team, application of up-to-date 3D CAD software in our in-house design department, employment of latest production technologies and LEAN quality management based on ISO 9001:2000 standard, have determined the rapid expansion of our sales markets and therefore the consequent quick growth of the company.*

*Currently, over 165 employees work in the enterprise and the production area covers 5000 m<sup>2</sup>. **Novameta** manufactures over 180 different items every day, more than 1000 projects yearly!*



**CONTENTS**

CUSTOMISED SOLUTIONS FOR BAR TABLES

STANDARD BAR EQUIPMENT

ADDITIONAL INFORMATION

**Novameta**

📍 Draugystės g. 15D, LT-51227 Kaunas, Lithuania  
 ☎ +370 37 30 23 30  
 ✉ novameta@novameta.lt  
 🌐 www.novameta.lt

**Novameta UK**

📍 1210 Parkview, Arlington Business Park, Theale, Reading, Berkshire RG7 4TY, UK  
 ☎ +44 118 965 4098  
 📞 +44 791 874 0027  
 ✉ sales@novameta.co.uk  
 🌐 www.novameta.co.uk



You can design your own table by using the wide range of components. **Novameta** bar equipment is a tailored blend of quality, flexibility and functionality to meet the needs of an individual bar.



Unlimited flexibility in design allows to create a functional workspace for bar staff, thus being able to provide fast service for a number of thirsty clients, which leads to satisfaction and loyalty of customers.



Possibility of tailoring bar units according to your projects for all types of venues – restaurants, hotels, pubs, bars of any style or even coffee shops.



Wide range of components and accessories that are easy to mix-and-match, when creating a solution to meet all the needs.



Every customized bar solution is followed with a detailed 3D drawing, when ordering. This guarantees satisfaction with the delivered product.



High-quality materials and sturdy welded construction makes the bar solutions durable and long lasting.



Ergonomically arranged layout allows to have all the tools for mixing, blending and serving close to hand, resulting in increased staff productivity and sales.



Hygienic design as well as welding and polishing for every unit or accessory.



Appealing and sophisticated looks allow our equipment to be installed in open-plan drink serving areas visible to customers.

**i** HOW IT WORKS?

**+** CHOOSE A TABLETOP OF NEEDED SIZE AND PROFILE/UPSTAND CONFIGURATION



**+** ADD EXTRA ELEMENTS TO THE TABLETOP (SINKS, BASINS, DRIP-TRAYS, SPEED-RACKS, ETC.)



**+** FINISH UP THE LAYOUT WITH THE CHOSEN TYPE OF FRAME COMBINATION



**=** CUSTOMISED BAR SOLUTION

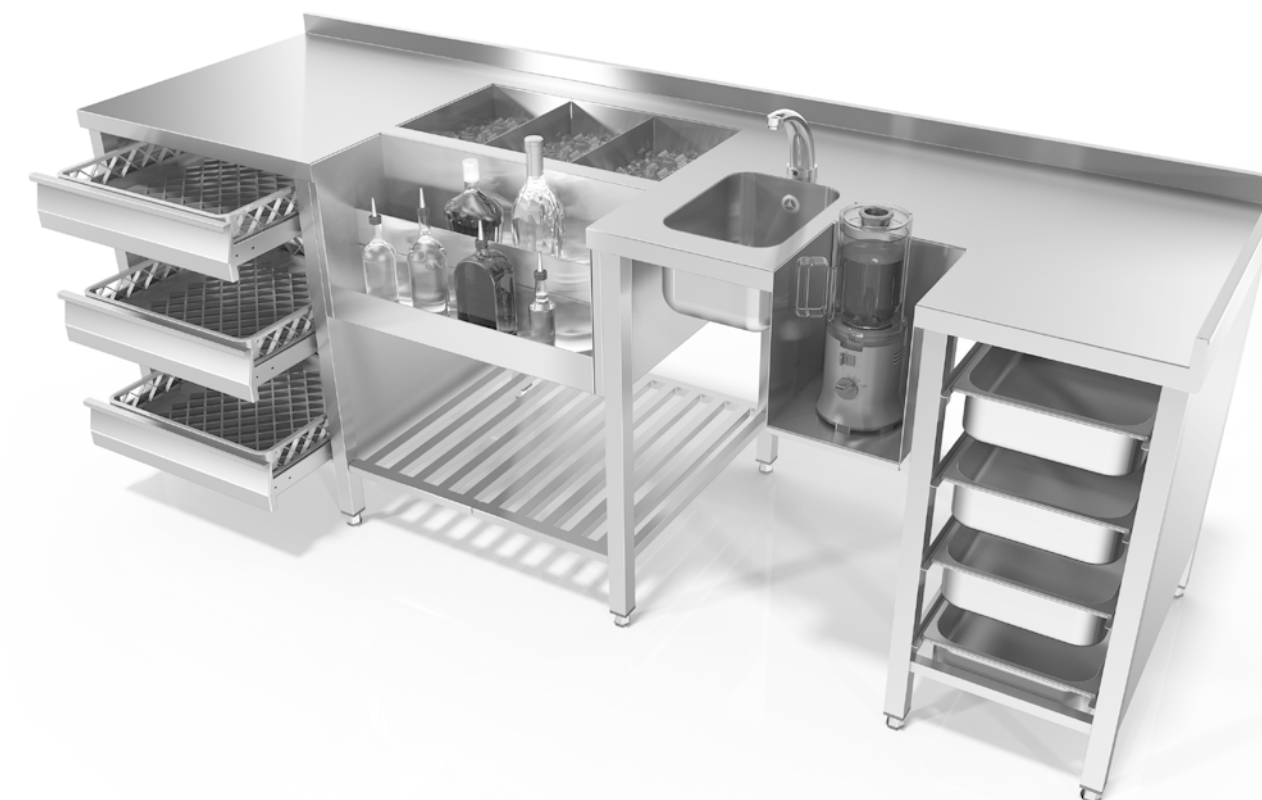

STANDARD FEATURES

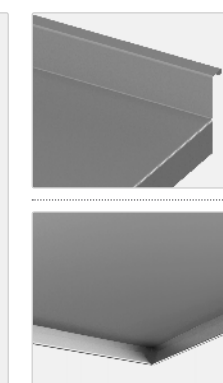
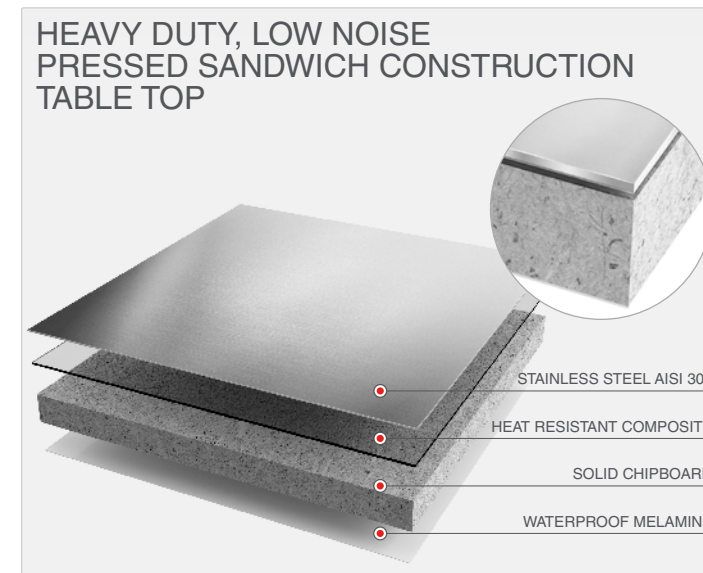
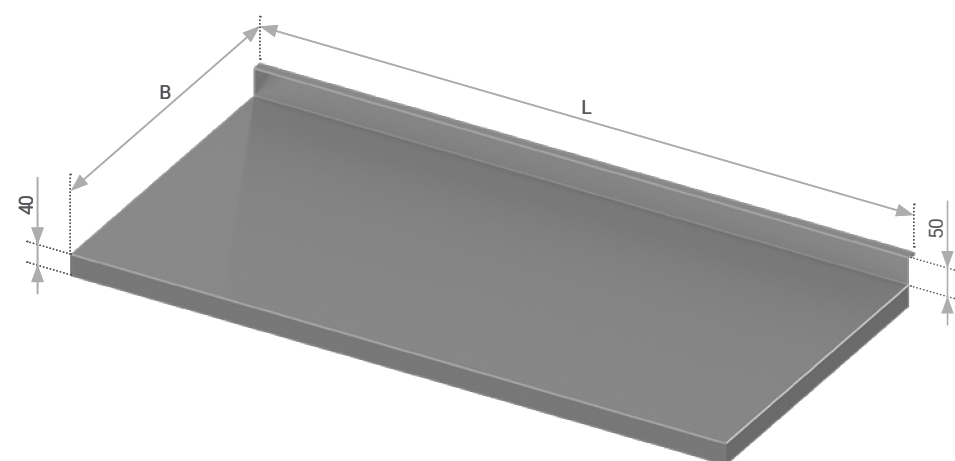

With or without upstand (all options on page 7.32)

Stainless steel table top for mounting on a frame (made of 1.5 mm sheet)

More accessories on page 7.32. Different dimensions and configurations are available on request. Examples on page 7.38.

Length L, mm	Width B, mm					
	600		650		700	
	Model	Price, €	Model	Price, €	Model	Price, €
400	Z-DP0-D00-40/60/4	143	Z-DP0-D00-40/65/4	145	Z-DP0-D00-40/70/4	148
500	Z-DP0-D00-50/60/4	150	Z-DP0-D00-50/65/4	153	Z-DP0-D00-50/70/4	156
600	Z-DP0-D00-60/60/4	158	Z-DP0-D00-60/65/4	161	Z-DP0-D00-60/70/4	164
700	Z-DP0-D00-70/60/4	164	Z-DP0-D00-70/65/4	169	Z-DP0-D00-70/70/4	172
800	Z-DP0-D00-80/60/4	172	Z-DP0-D00-80/65/4	176	Z-DP0-D00-80/70/4	180
900	Z-DP0-D00-90/60/4	178	Z-DP0-D00-90/65/4	184	Z-DP0-D00-90/70/4	189
1000	Z-DP0-D00-100/60/4	186	Z-DP0-D00-100/65/4	191	Z-DP0-D00-100/70/4	197
1100	Z-DP0-D00-110/60/4	192	Z-DP0-D00-110/65/4	198	Z-DP0-D00-110/70/4	205
1200	Z-DP0-D00-120/60/4	200	Z-DP0-D00-120/65/4	206	Z-DP0-D00-120/70/4	213
1300	Z-DP0-D00-130/60/4	222	Z-DP0-D00-130/65/4	230	Z-DP0-D00-130/70/4	238
1400	Z-DP0-D00-140/60/4	230	Z-DP0-D00-140/65/4	238	Z-DP0-D00-140/70/4	247
1500	Z-DP0-D00-150/60/4	238	Z-DP0-D00-150/65/4	247	Z-DP0-D00-150/70/4	257
1600	Z-DP0-D00-160/60/4	246	Z-DP0-D00-160/65/4	257	Z-DP0-D00-160/70/4	266
1700	Z-DP0-D00-170/60/4	255	Z-DP0-D00-170/65/4	265	Z-DP0-D00-170/70/4	276
1800	Z-DP0-D00-180/60/4	263	Z-DP0-D00-180/65/4	274	Z-DP0-D00-180/70/4	285
1900	Z-DP0-D00-190/60/4	271	Z-DP0-D00-190/65/4	282	Z-DP0-D00-190/70/4	295
2000	Z-DP0-D00-200/60/4	279	Z-DP0-D00-200/65/4	291	Z-DP0-D00-200/70/4	304
2100	Z-DP0-D00-210/60/4	287	Z-DP0-D00-210/65/4	299	Z-DP0-D00-210/70/4	313
2200	Z-DP0-D00-220/60/4	296	Z-DP0-D00-220/65/4	309	Z-DP0-D00-220/70/4	321
2300	Z-DP0-D00-230/60/4	304	Z-DP0-D00-230/65/4	318	Z-DP0-D00-230/70/4	331
2400	Z-DP0-D00-240/60/4	312	Z-DP0-D00-240/65/4	326	Z-DP0-D00-240/70/4	340
2500	Z-DP0-D00-250/60/4	320	Z-DP0-D00-250/65/4	335	Z-DP0-D00-250/70/4	350
2600	Z-DP0-D00-260/60/4	328	Z-DP0-D00-260/65/4	343	Z-DP0-D00-260/70/4	359
2700	Z-DP0-D00-270/60/4	337	Z-DP0-D00-270/65/4	353	Z-DP0-D00-270/70/4	369
2800	Z-DP0-D00-280/60/4	345	Z-DP0-D00-280/65/4	361	Z-DP0-D00-280/70/4	378
2900	Z-DP0-D00-290/60/4	353	Z-DP0-D00-290/65/4	370	Z-DP0-D00-290/70/4	387
3000	Z-DP0-D00-300/60/4	591	Z-DP0-D00-300/65/4	617	Z-DP0-D00-300/70/4	644
3100	Z-DP0-D00-310/60/4	602	Z-DP0-D00-310/65/4	630	Z-DP0-D00-310/70/4	657
3200	Z-DP0-D00-320/60/4	615	Z-DP0-D00-320/65/4	644	Z-DP0-D00-320/70/4	672
3300	Z-DP0-D00-330/60/4	627	Z-DP0-D00-330/65/4	655	Z-DP0-D00-330/70/4	685
3400	Z-DP0-D00-340/60/4	639	Z-DP0-D00-340/65/4	668	Z-DP0-D00-340/70/4	698
3500	Z-DP0-D00-350/60/4	650	Z-DP0-D00-350/65/4	681	Z-DP0-D00-350/70/4	713
3600	Z-DP0-D00-360/60/4	663	Z-DP0-D00-360/65/4	695	Z-DP0-D00-360/70/4	726
3700	Z-DP0-D00-370/60/4	675	Z-DP0-D00-370/65/4	708	Z-DP0-D00-370/70/4	739
3800	Z-DP0-D00-380/60/4	686	Z-DP0-D00-380/65/4	719	Z-DP0-D00-380/70/4	754
3900	Z-DP0-D00-390/60/4	700	Z-DP0-D00-390/65/4	733	Z-DP0-D00-390/70/4	767
4000	Z-DP0-D00-400/60/4	711	Z-DP0-D00-400/65/4	746	Z-DP0-D00-400/70/4	780

OPTIONAL FEATURES

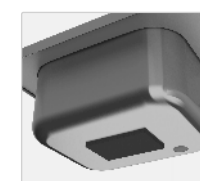

**Sinks with noise dampening pads**  
All options on page 7.33



**Plumbing sets**  
All options on page 7.32



**Deepened table top**  
Code: DG0  
Price: 172 €

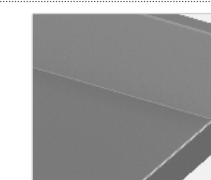

**Customised upstand (height 40 - 100 mm)**  
Code: A-DSB-A  
Price: 35 €



**Waste hole for coffee grinder (250 x 200 mm)**  
Code: Z-C-HOLE  
Price: 135 €

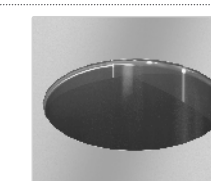

**Stainless steel waste hole (Ø150, Ø200 or Ø250 mm)**  
Code: Y-SNA  
Price: 72 €

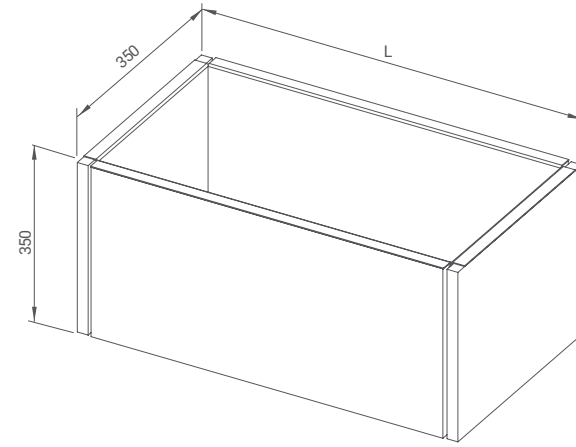
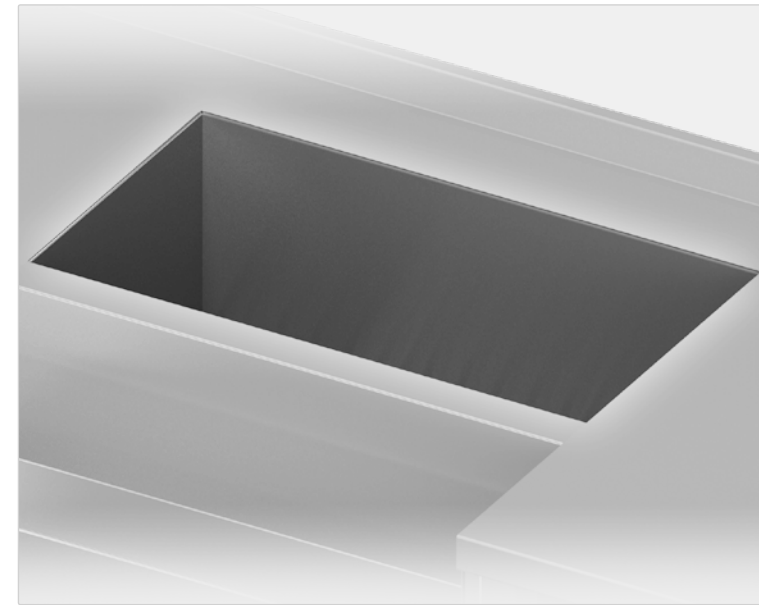

Length L, mm	Width B, mm		Price, €
	350		
	Model		
500	Z-ICEB-50/35/35		250
600	Z-ICEB-60/35/35		260
700	Z-ICEB-70/35/35		270
800	Z-ICEB-80/35/35		290
900	Z-ICEB-90/35/35		310
1000	Z-ICEB-100/35/35		330

*i* Different dimensions and configurations are available on request. Examples on page 7.38.

**STANDARD FEATURES**

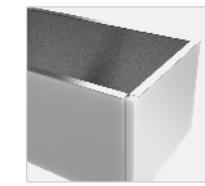

Efficient 20 mm polystyrene thermal insulation



Built-in design, hygienic welding

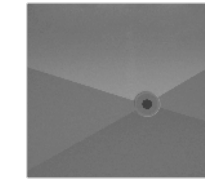

Drain grooves for water run-off



Water outlet connection in the centre (external thread G1/2)

**OPTIONAL FEATURES**

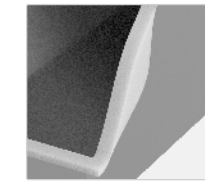

**Thermal insulation covered with stainless steel**

Code: Z-COVER  
Price: 110 €

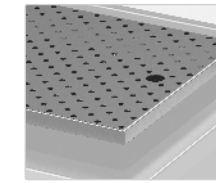

**Removable drainboard (height: 20 mm)**

Code: Z-D-BOARD  
Price/100 mm: 7 €

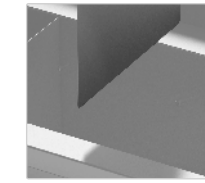

**Removable partitions**

Code: Z-R-PARTITIONS  
Price: 25 €  
Note: price per partition

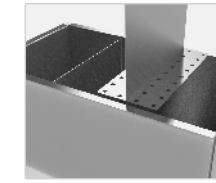

**Sliding partitions**

Code: Z-S-PARTITIONS  
Price: 25 €  
Note: price per partition

ICE BASIN FOR BOTTLES

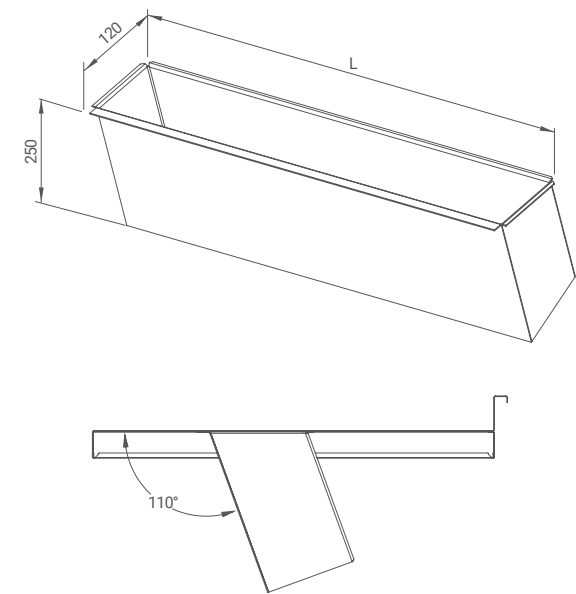
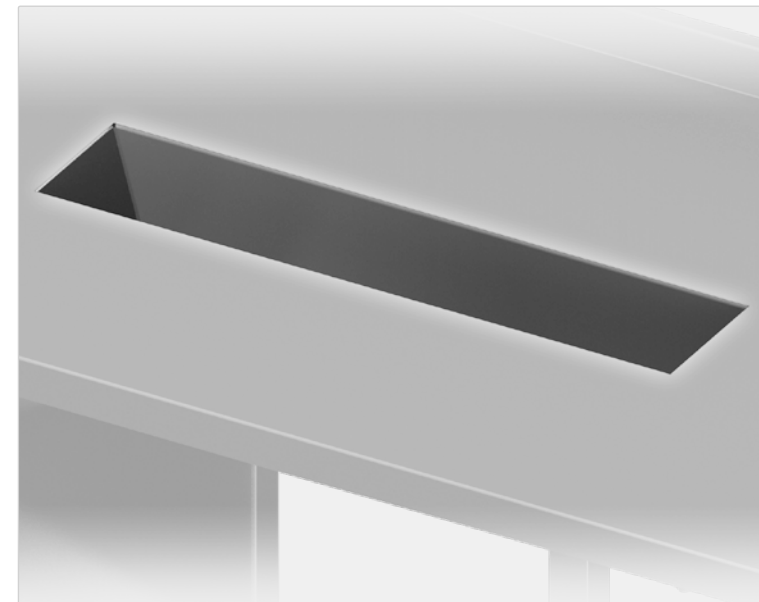

Length L, mm	Width B, mm		Price, €
	100		
	Model		
500	Z-BOTB-50/12/25		210
600	Z-BOTB-60/12/25		220
700	Z-BOTB-70/12/25		230
800	Z-BOTB-80/12/25		240
900	Z-BOTB-90/12/25		256
1000	Z-BOTB-100/12/25		271

*i* Different dimensions and configurations are available on request. Examples on page 7.38.

**STANDARD FEATURES**

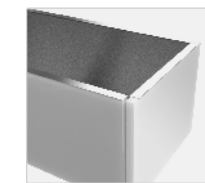

Efficient 20 mm polystyrene thermal insulation

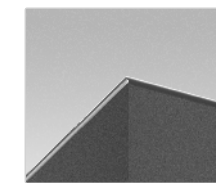

Built-in design, hygienic welding

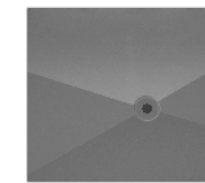

Drain grooves for water run-off



Water outlet connection in the centre (external thread G1/2)

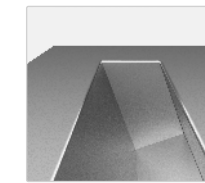

110° angled basin for increased ergonomics

**OPTIONAL FEATURES**

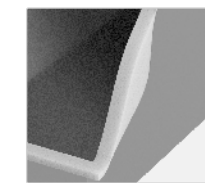

**Thermal insulation covered with stainless steel**

Code: Z-COVER  
Price: 70 €

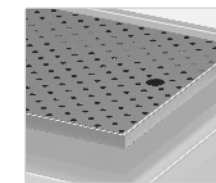

**Removable drainboard (height: 20 mm)**

Code: Z-D-BOARD  
Price/100 mm: 5 €

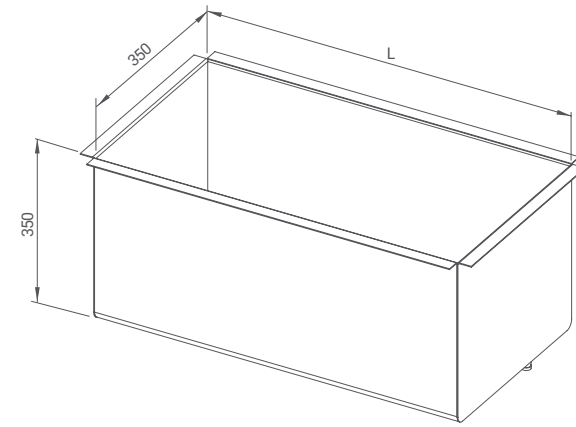
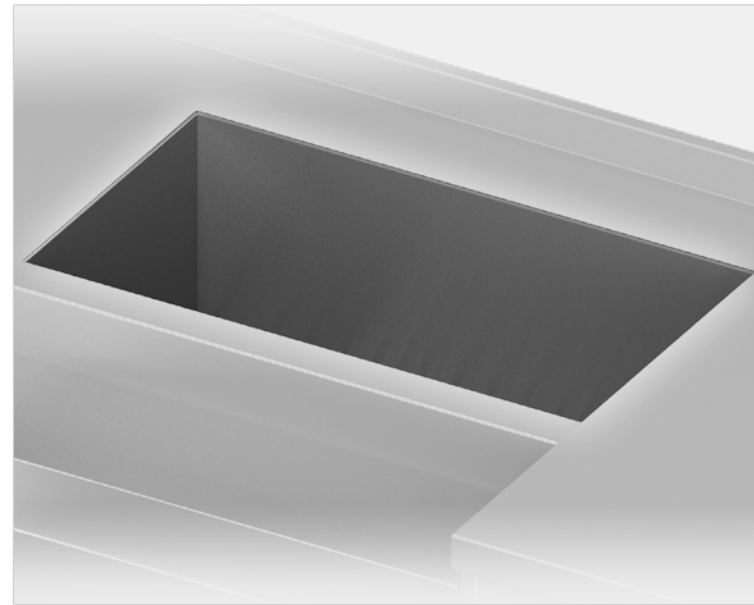

Length L, mm	Width B, mm		Price, €
	350		
	Model		
500	Y-PLV-50/35/35		200
600	Y-PLV-60/35/35		210
700	Y-PLV-70/35/35		220
800	Y-PLV-80/35/35		235
900	Y-PLV-90/35/35		245
1000	Y-PLV-100/35/35		260

*i* Different dimensions and configurations are available on request. Examples on page 7.38.

**STANDARD FEATURES**

ROUNDED CORNERS FOR EASY CLEANING

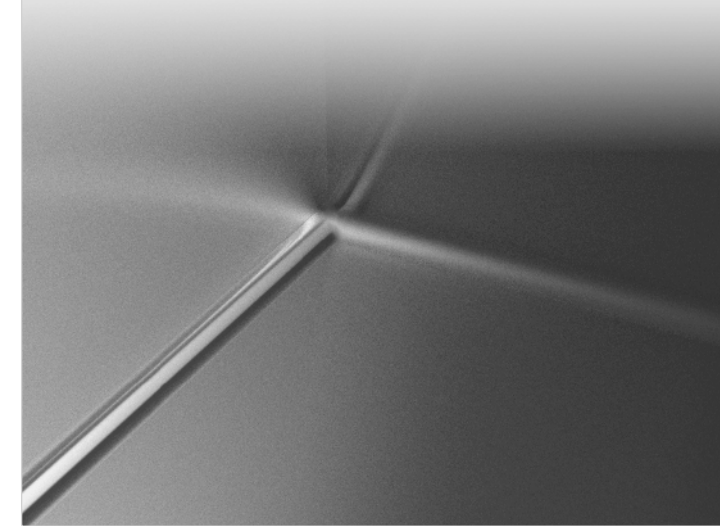

Water outlet connection in the centre (external thread G1/2)

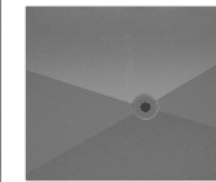

Drain grooves for water run-off

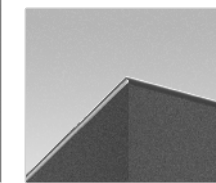

Built-in design, hygienic welding

**OPTIONAL FEATURES**



**Strainer**

Code: A-PL-PR1  
Price: 10 €

WELDED SHELF FOR BLENDER

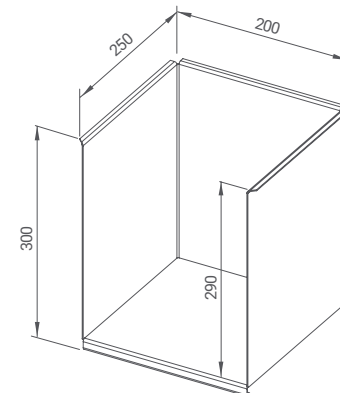
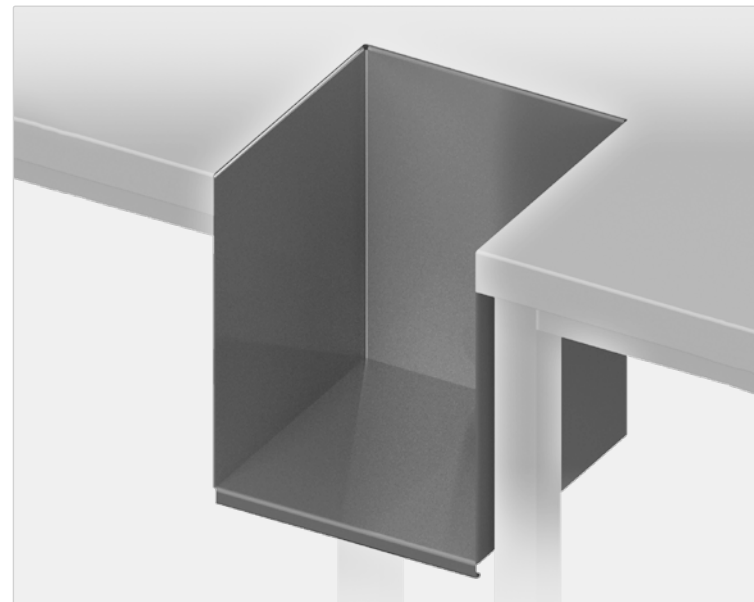

Length L, mm	Width B, mm		Price, €
	250		
	Model		
200	Z-SFB1-20/25/30		175

*i* Different dimensions and configurations are available on request. Examples on page 7.38.

**STANDARD FEATURES**

DESIGNED FOR BLENDER

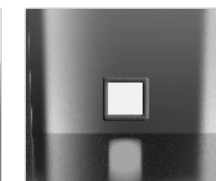

Power cord access hole with 50 x 50 mm grommet

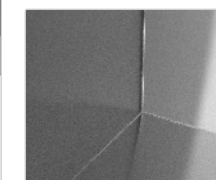

Durable welded construction



Built-in design, hygienic welding

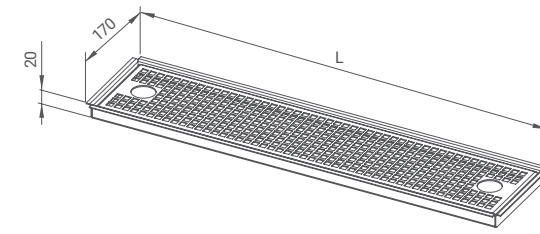
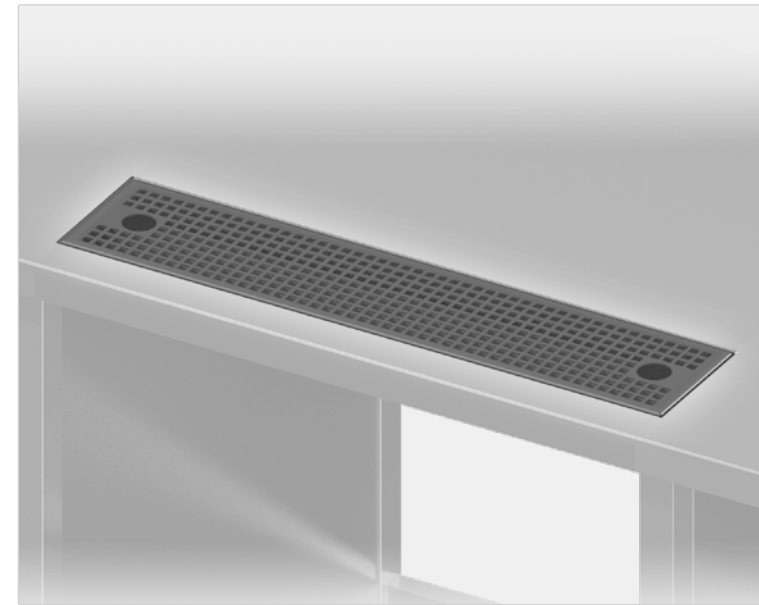

Length L, mm	Width B, mm		Price, €
	170		
	Model		
500	Z-DTFB-50/17/2		243
600	Z-DTFB-60/17/2		255
700	Z-DTFB-70/17/2		268
800	Z-DTFB-80/17/2		280
900	Z-DTFB-90/17/2		293
1000	Z-DTFB-100/17/2		305

*i* Different dimensions and configurations are available on request. Examples on page 7.38.

**STANDARD FEATURES**

REMOVABLE DRAINBOARD

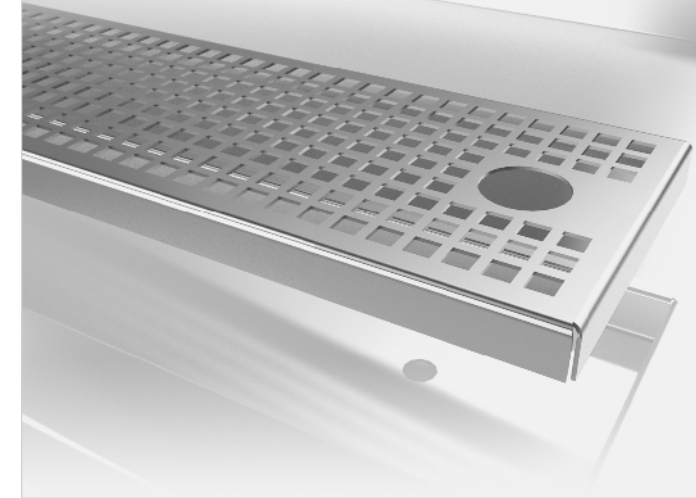

Water outlet connection in the centre (external thread G1/2)

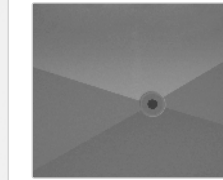

Drain grooves for water run-off

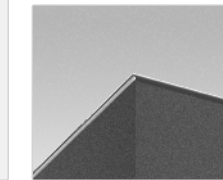

Built-in design, hygienic welding

**OPTIONAL FEATURES**

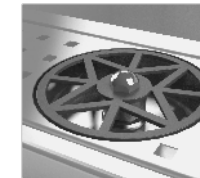

**Glass rinser**

Code: N-SDS  
Price: 155 €

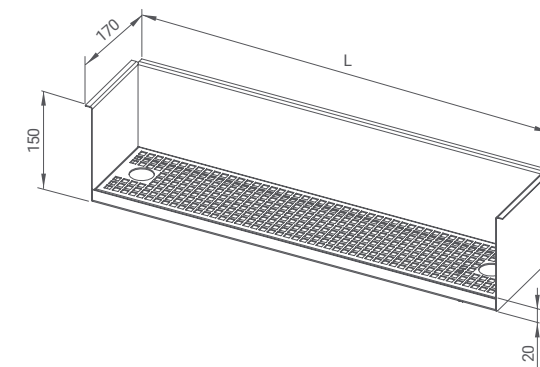

Length L, mm	Width B, mm		Price, €
	170		
	Model		
500	Z-DTFC-50/17/15		226
600	Z-DTFC-60/17/15		239
700	Z-DTFC-70/17/15		251
800	Z-DTFC-80/17/15		264
900	Z-DTFC-90/17/15		276
1000	Z-DTFC-100/17/15		288

*i* Different dimensions and configurations are available on request. Examples on page 7.38.

**STANDARD FEATURES**

REMOVABLE DRAINBOARD

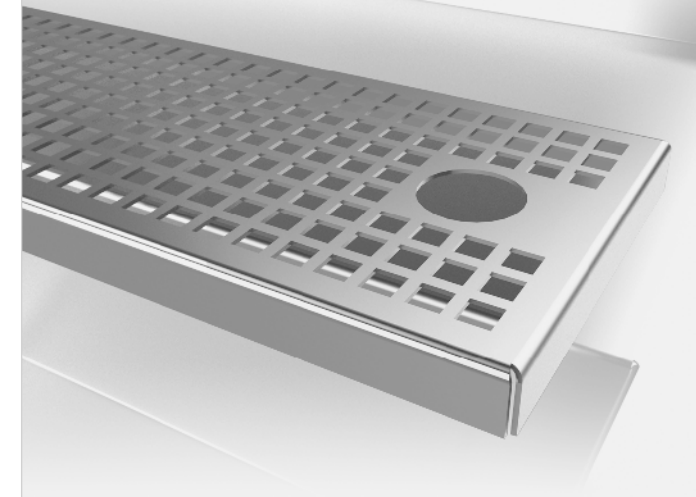

Water outlet connection in the centre (external thread G1/2)

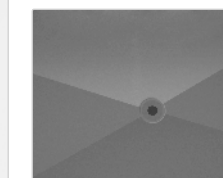

Drain grooves for water run-off



Built-in design, hygienic welding

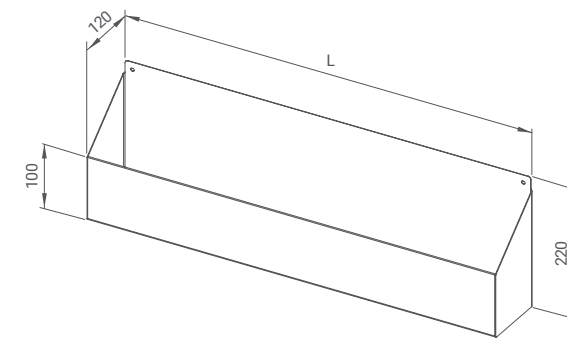
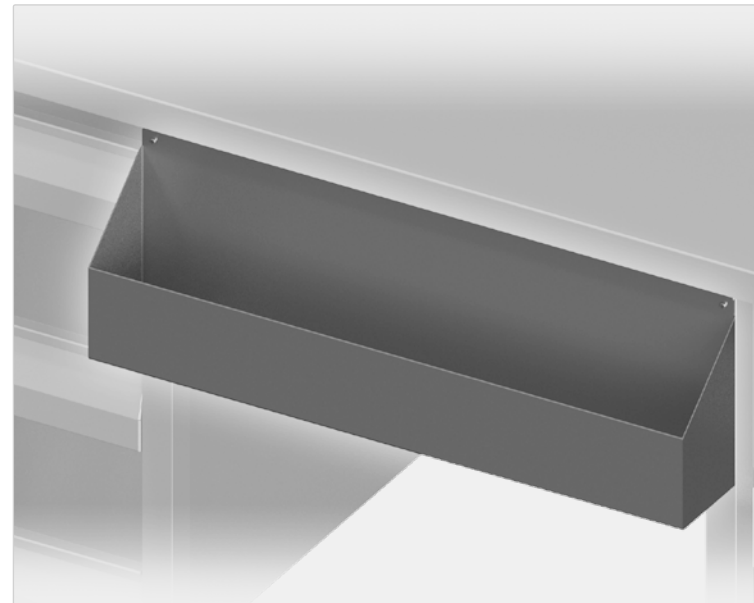

Length L, mm	Width B, mm		Price, €
	120		
	Model		
500	Z-MSR1-50/12/22		81
600	Z-MSR1-60/12/22		89
700	Z-MSR1-70/12/22		97
800	Z-MSR1-80/12/22		105
900	Z-MSR1-90/12/22		113
1000	Z-MSR1-100/12/22		121

*i* Different dimensions and configurations are available on request. Examples on page 7.38.

**STANDARD FEATURES**

DESIGNED FOR BOTTLES

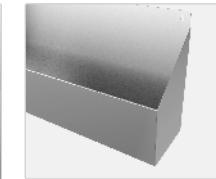

Single section

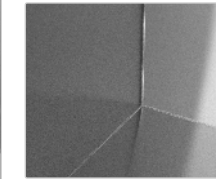

Durable welded construction

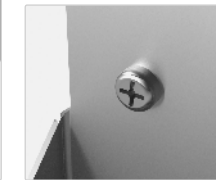

Easy to mount on any surface

MOUNTED SPEED RACK DOUBLE

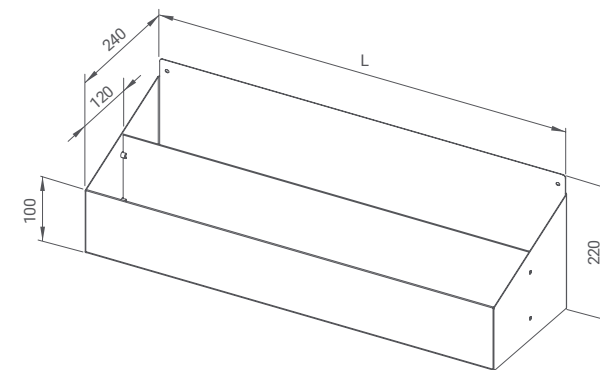
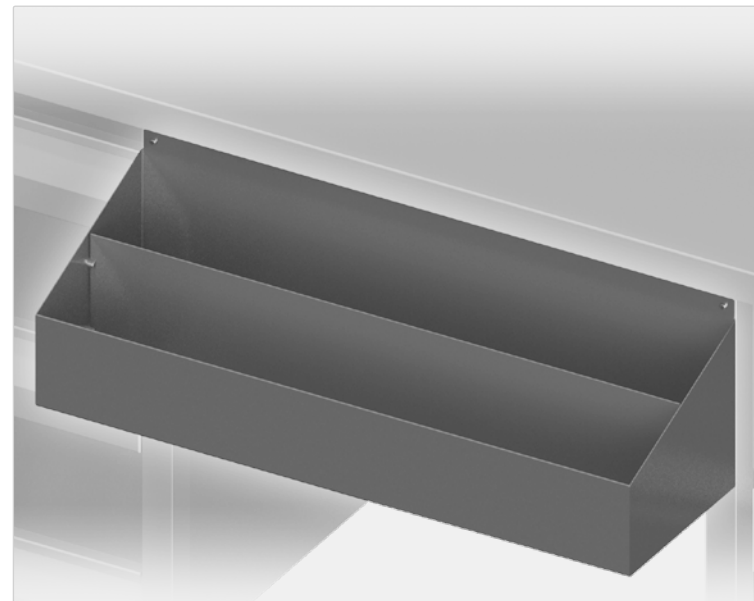

Length L, mm	Width B, mm		Price, €
	240		
	Model		
500	Z-MSR2-50/24/22		147
600	Z-MSR2-60/24/22		161
700	Z-MSR2-70/24/22		175
800	Z-MSR2-80/24/22		189
900	Z-MSR2-90/24/22		203
1000	Z-MSR2-100/24/22		217

*i* Different dimensions and configurations are available on request. Examples on page 7.38.

**STANDARD FEATURES**

DESIGNED FOR BOTTLES

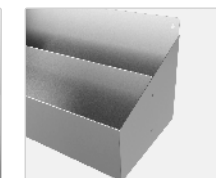

Double section, removable partition

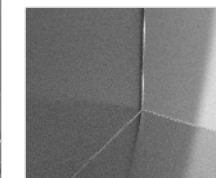

Durable welded construction

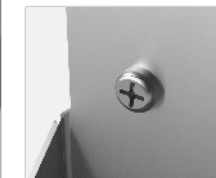

Easy to mount on any surface



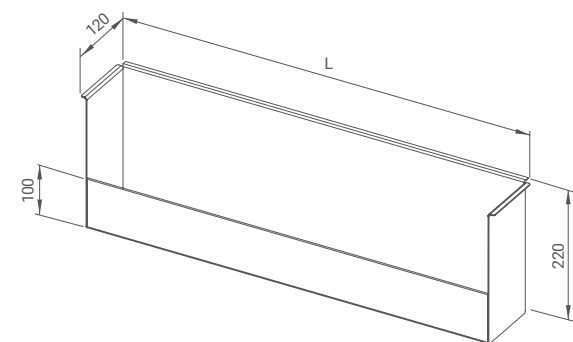
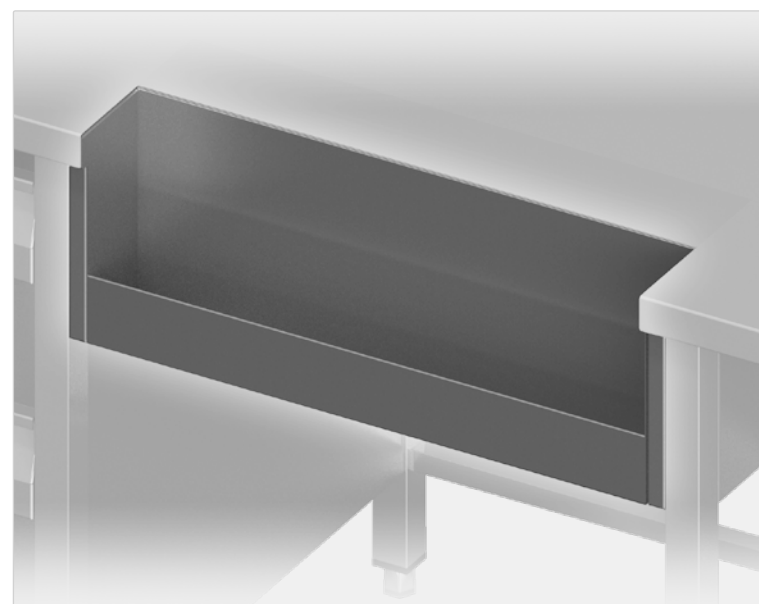

Length L, mm	Width B, mm		Price, €
	120		
	Model		
500	Z-WSR1-50/12/22		208
600	Z-WSR1-60/12/22		220
700	Z-WSR1-70/12/22		233
800	Z-WSR1-80/12/22		245
900	Z-WSR1-90/12/22		258
1000	Z-WSR1-100/12/22		270

*i* Different dimensions and configurations are available on request. Examples on page 7.38.

STANDARD FEATURES

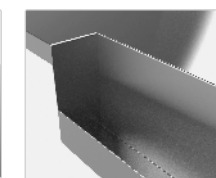

Single section

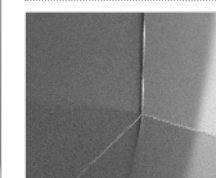

Durable welded construction

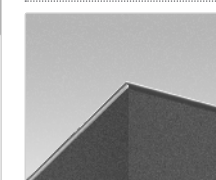

Built-in design, hygienic welding

WELDED SPEED RACK DOUBLE

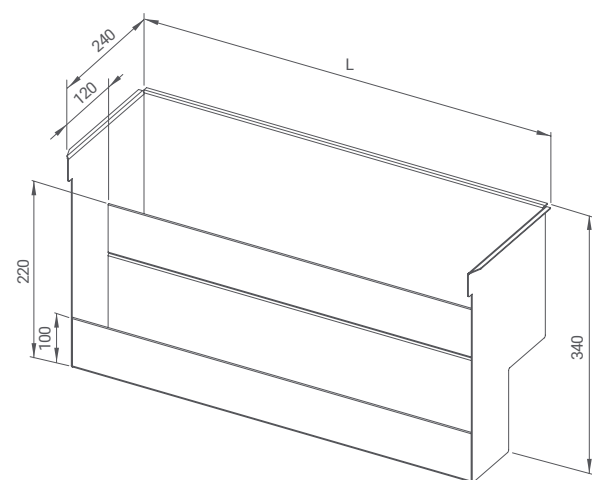
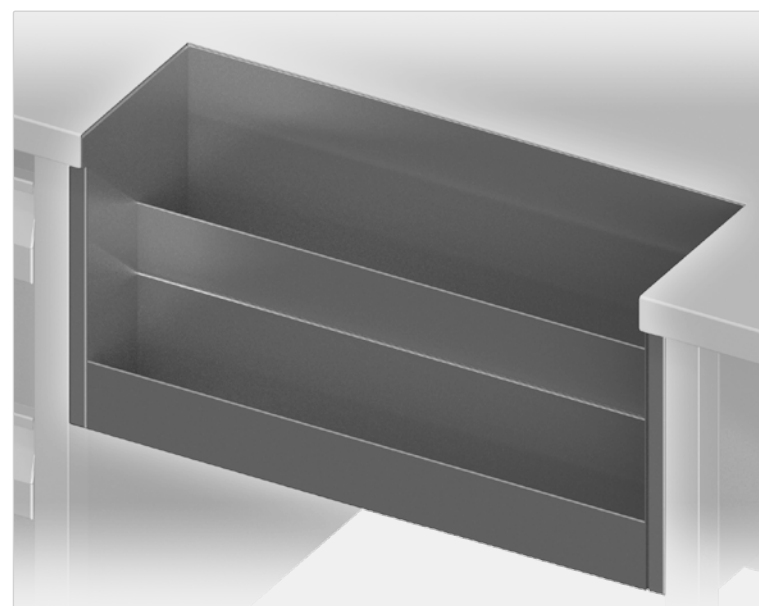

Length L, mm	Width B, mm		Price, €
	240		
	Model		
500	Z-WSR2-50/24/34		284
600	Z-WSR2-60/24/34		300
700	Z-WSR2-70/24/34		316
800	Z-WSR2-80/24/34		332
900	Z-WSR2-90/24/34		348
1000	Z-WSR2-100/24/34		364

*i* Different dimensions and configurations are available on request. Examples on page 7.38.

STANDARD FEATURES

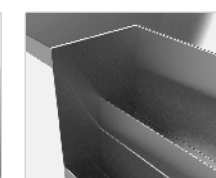

Double section

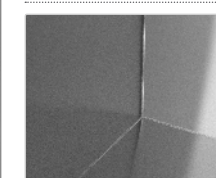

Durable welded construction

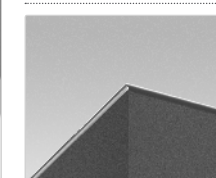

Built-in design, hygienic welding

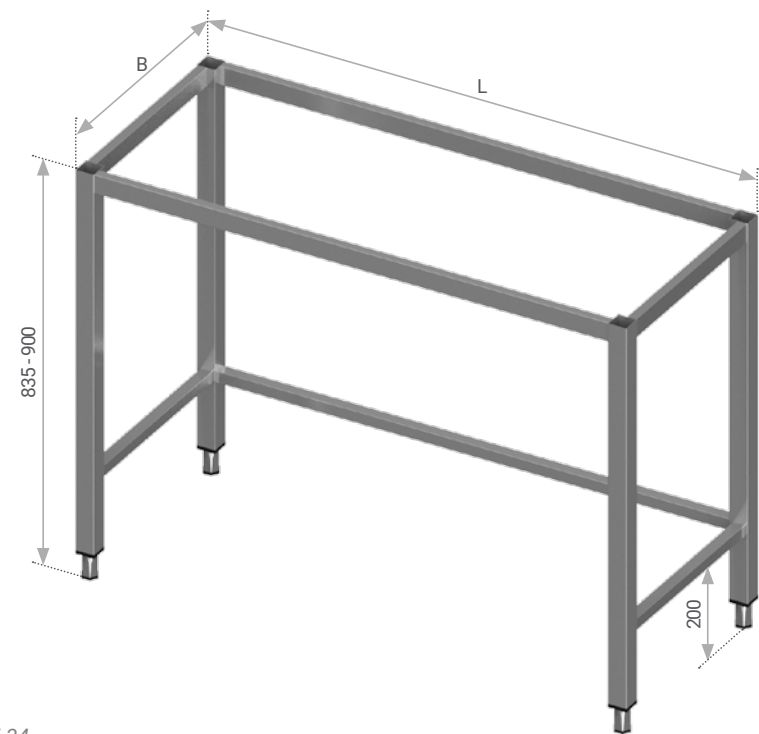

More accessories on page 7.34.  
Different dimensions and configurations are available on request. Examples on page 7.38.

Length L, mm	Width B, mm						Legs
	600		650		700		
	Model	Price, €	Model	Price, €	Model	Price, €	
400	Z-D00-PRV-40/60/87	127	Z-D00-PRV-40/65/87	130	Z-D00-PRV-40/70/87	132	4
500	Z-D00-PRV-50/60/87	134	Z-D00-PRV-50/65/87	136	Z-D00-PRV-50/70/87	138	4
600	Z-D00-PRV-60/60/87	140	Z-D00-PRV-60/65/87	143	Z-D00-PRV-60/70/87	145	4
700	Z-D00-PRV-70/60/87	146	Z-D00-PRV-70/65/87	149	Z-D00-PRV-70/70/87	152	4
800	Z-D00-PRV-80/60/87	152	Z-D00-PRV-80/65/87	155	Z-D00-PRV-80/70/87	158	4
900	Z-D00-PRV-90/60/87	159	Z-D00-PRV-90/65/87	161	Z-D00-PRV-90/70/87	165	4
1000	Z-D00-PRV-100/60/87	165	Z-D00-PRV-100/65/87	169	Z-D00-PRV-100/70/87	172	4
1100	Z-D00-PRV-110/60/87	171	Z-D00-PRV-110/65/87	175	Z-D00-PRV-110/70/87	178	4
1200	Z-D00-PRV-120/60/87	177	Z-D00-PRV-120/65/87	181	Z-D00-PRV-120/70/87	185	4
1300	Z-D00-PRV-130/60/87	179	Z-D00-PRV-130/65/87	183	Z-D00-PRV-130/70/87	187	4
1400	Z-D00-PRV-140/60/87	185	Z-D00-PRV-140/65/87	189	Z-D00-PRV-140/70/87	193	4
1500	Z-D00-PRV-150/60/87	191	Z-D00-PRV-150/65/87	195	Z-D00-PRV-150/70/87	199	4
1600	Z-D00-PRV-160/60/87	197	Z-D00-PRV-160/65/87	201	Z-D00-PRV-160/70/87	205	4
1700	Z-D00-PRV-170/60/87	203	Z-D00-PRV-170/65/87	207	Z-D00-PRV-170/70/87	211	4
1800	Z-D00-PRV-180/60/87	209	Z-D00-PRV-180/65/87	214	Z-D00-PRV-180/70/87	217	4
1900	Z-D00-PRV-190/60/87	215	Z-D00-PRV-190/65/87	220	Z-D00-PRV-190/70/87	223	4
2000	Z-D00-PRV-200/60/87	221	Z-D00-PRV-200/65/87	225	Z-D00-PRV-200/70/87	230	4
2100	Z-D00-PRV-210/60/87	290	Z-D00-PRV-210/65/87	295	Z-D00-PRV-210/70/87	300	6
2200	Z-D00-PRV-220/60/87	295	Z-D00-PRV-220/65/87	301	Z-D00-PRV-220/70/87	306	6
2300	Z-D00-PRV-230/60/87	302	Z-D00-PRV-230/65/87	307	Z-D00-PRV-230/70/87	312	6
2400	Z-D00-PRV-240/60/87	308	Z-D00-PRV-240/65/87	313	Z-D00-PRV-240/70/87	319	6
2500	Z-D00-PRV-250/60/87	314	Z-D00-PRV-250/65/87	319	Z-D00-PRV-250/70/87	325	6
2600	Z-D00-PRV-260/60/87	320	Z-D00-PRV-260/65/87	325	Z-D00-PRV-260/70/87	331	6
2700	Z-D00-PRV-270/60/87	325	Z-D00-PRV-270/65/87	331	Z-D00-PRV-270/70/87	337	6
2800	Z-D00-PRV-280/60/87	331	Z-D00-PRV-280/65/87	337	Z-D00-PRV-280/70/87	343	6
2900	Z-D00-PRV-290/60/87	337	Z-D00-PRV-290/65/87	344	Z-D00-PRV-290/70/87	350	6
3000	Z-D00-PRV-300/60/87	444	Z-D00-PRV-300/65/87	454	Z-D00-PRV-300/70/87	463	6
3100	Z-D00-PRV-310/60/87	451	Z-D00-PRV-310/65/87	460	Z-D00-PRV-310/70/87	470	6
3200	Z-D00-PRV-320/60/87	456	Z-D00-PRV-320/65/87	466	Z-D00-PRV-320/70/87	476	6
3300	Z-D00-PRV-330/60/87	462	Z-D00-PRV-330/65/87	472	Z-D00-PRV-330/70/87	482	6
3400	Z-D00-PRV-340/60/87	468	Z-D00-PRV-340/65/87	478	Z-D00-PRV-340/70/87	489	6
3500	Z-D00-PRV-350/60/87	474	Z-D00-PRV-350/65/87	484	Z-D00-PRV-350/70/87	495	6
3600	Z-D00-PRV-360/60/87	550	Z-D00-PRV-360/65/87	562	Z-D00-PRV-360/70/87	573	8
3700	Z-D00-PRV-370/60/87	555	Z-D00-PRV-370/65/87	568	Z-D00-PRV-370/70/87	580	8
3800	Z-D00-PRV-380/60/87	562	Z-D00-PRV-380/65/87	574	Z-D00-PRV-380/70/87	586	8
3900	Z-D00-PRV-390/60/87	568	Z-D00-PRV-390/65/87	580	Z-D00-PRV-390/70/87	593	8
4000	Z-D00-PRV-400/60/87	573	Z-D00-PRV-400/65/87	586	Z-D00-PRV-400/70/87	600	8

STANDARD FEATURES

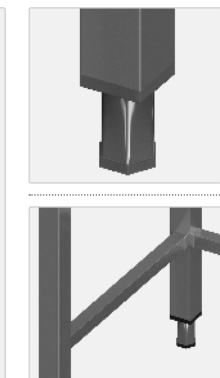
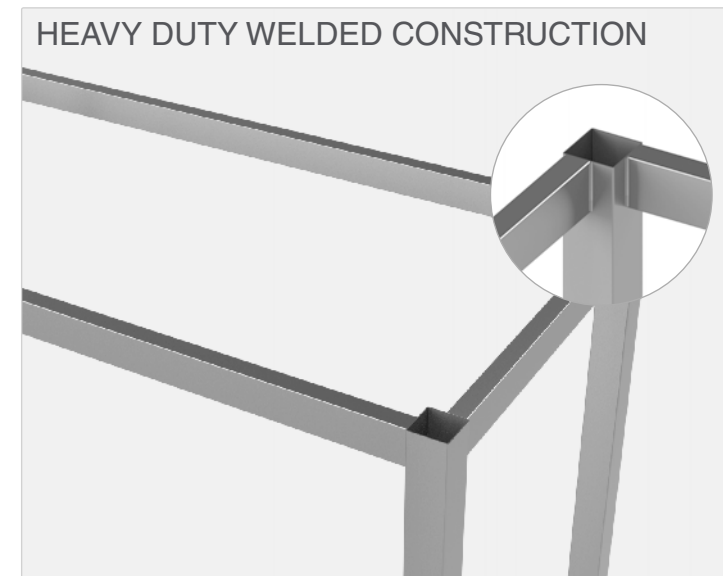

Adjustable stainless steel feet  
(amplitude 65 mm +30/-35)

Welded frame  
Legs made of stainless steel tube 40 x 40 mm  
Frame made of stainless steel tube 25 x 25 mm

OPTIONAL FEATURES

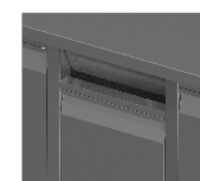

**Integrated waste chute above door**  
Code: Z-AD-WINDOW  
Price: 115 €

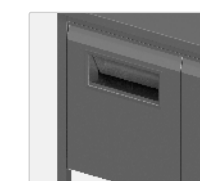

**Integrated waste chute on door**  
Code: Z-OD-WINDOW  
Price: 130 €

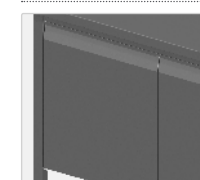

**Stainless steel shutting doors**  
Code: Z-VLU  
Price/100 mm: 28 €



**Stainless steel drawers**  
All options on page 7.34

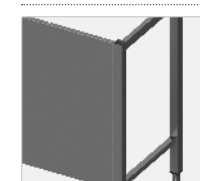

**Rear panel**  
Code: A-DSU-G  
Price/m: 45 €

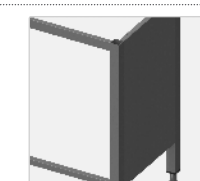

**Side panel**  
Code: A-DSU-K (left)  
A-DSU-D (right)  
Price/pc: 39 €



**Extra pair of legs**  
Code: Z-LEGS  
Price: 60 €



**Modular stainless steel shelf**  
Code: Z-A-MSL-Z  
Price: Ask for price

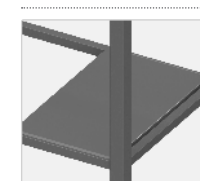

**Modular stainless steel plate shelf**  
Code: Z-A-MSL-P  
Price: Ask for price

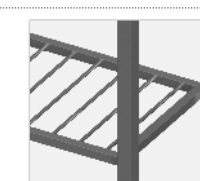

**Stainless steel grid shelf**  
Code: Z-D00-PSV  
Price: Ask for price

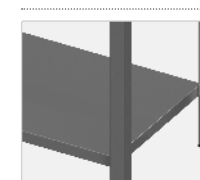

**Stainless steel reinforced shelf**  
Code: Z-D00-PLV  
Price: Ask for price

**STANDARD FEATURES**

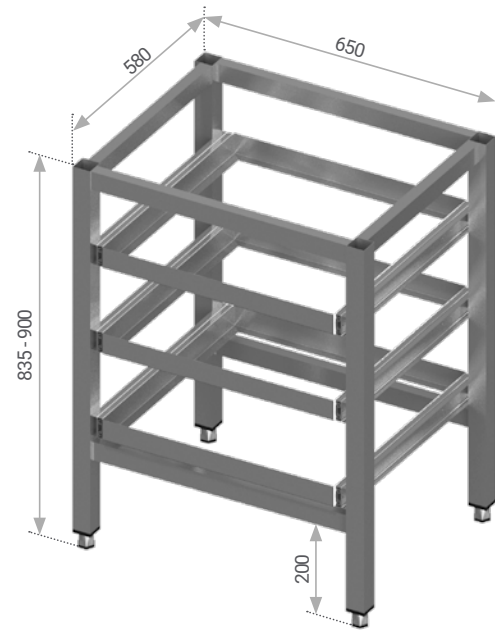

*Information icon* Different dimensions and configurations are available on request. Examples on page 7.38.

Length L, mm	Width B, mm		Model	Price, €
	580			
650			Z-BFD-65/58/87	358

SLIDING DRAWERS FOR BASKETS

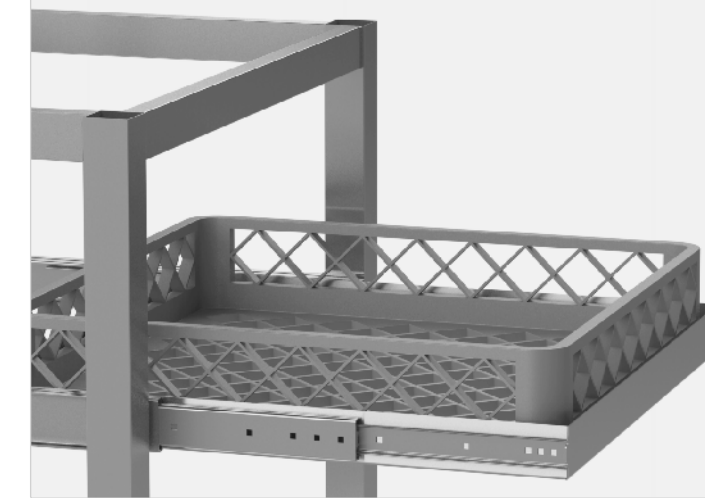

Adjustable stainless steel feet (amplitude 65 mm +30/-35)

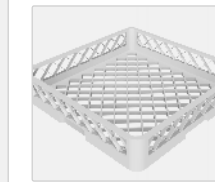

Designed for dishwasher baskets 500 x 500 mm

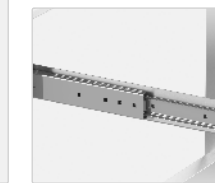

Durable telescopic rails

FRAME WITH DRAWERS FOR DISHWASHER BASKETS

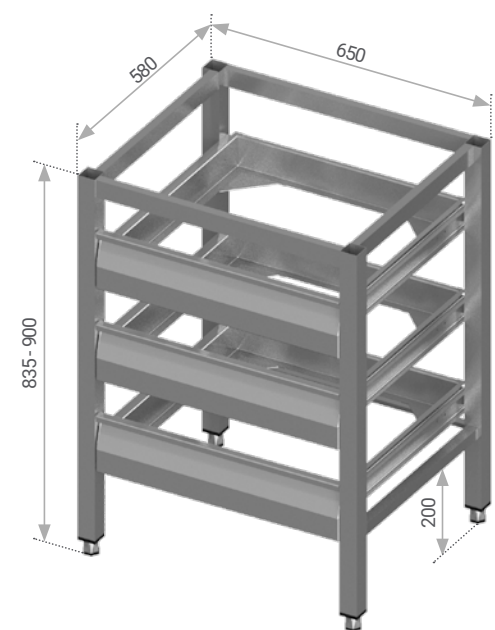

*Information icon* Different dimensions and configurations are available on request. Examples on page 7.38.

Length L, mm	Width B, mm		Model	Price, €
	580			
650			Z-BFDC-65/58/87	443

SLIDING DRAWERS FOR BASKETS WITH FRONT COVERS

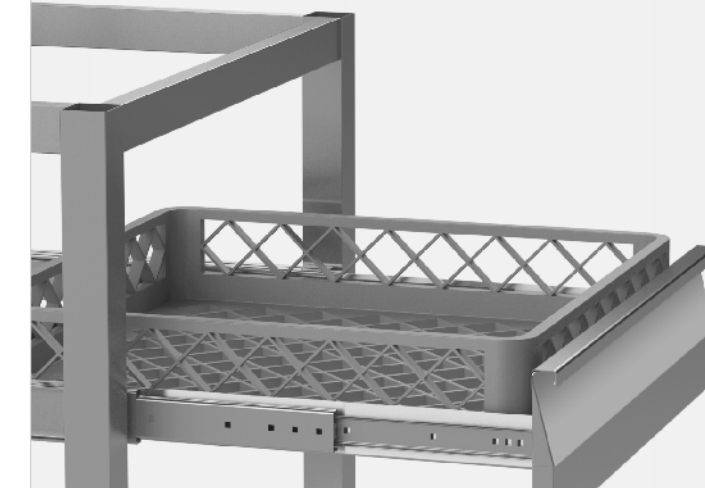

Adjustable stainless steel feet (amplitude 65 mm +30/-35)



Designed for dishwasher baskets 500 x 500 mm



Durable telescopic rails

**STANDARD FEATURES**

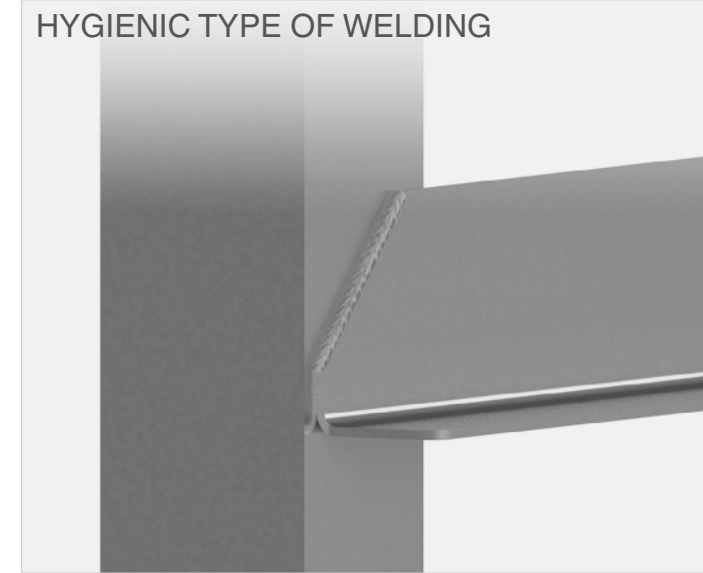
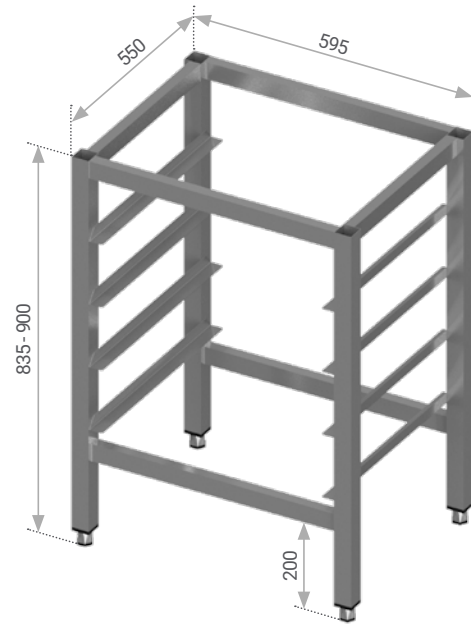

Adjustable stainless steel feet  
(amplitude 65 mm +30/-35)

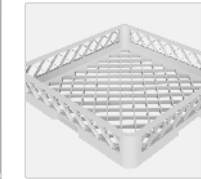

Designed for dishwasher baskets 500 x 500 mm

*Information icon* Different dimensions and configurations are available on request. Examples on page 7.38.

Length L, mm	Width B, mm		Guides	Distance between guides, mm
	550			
	Model	Price, €		
595	Z-BFG-59/55/87	187	4 pairs	145

FRAME WITH GUIDES FOR GASTRONORM CONTAINERS

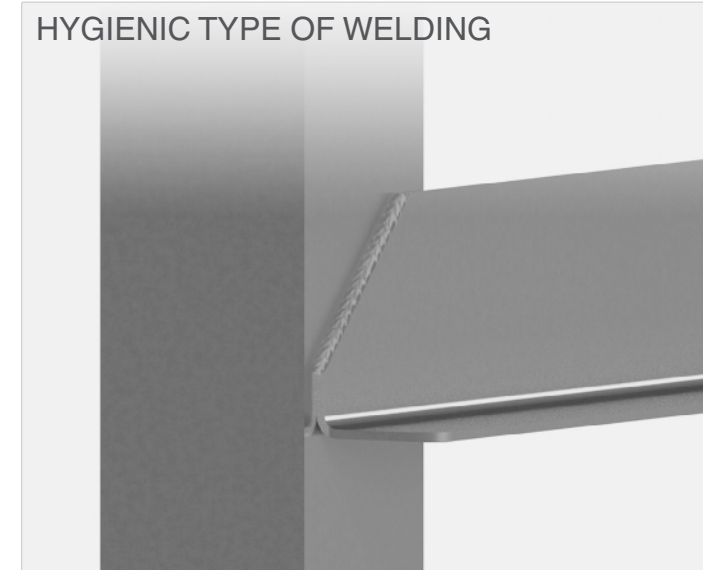
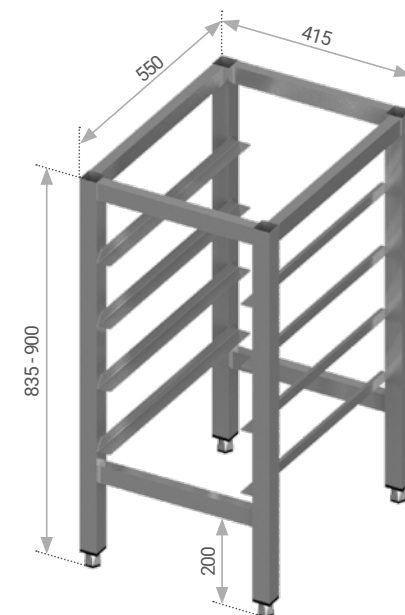

Adjustable stainless steel feet  
(amplitude 65 mm +30/-35)



Designed for GN 1/1 containers 325 x 530 mm

*Information icon* Different dimensions and configurations are available on request. Examples on page 7.38.

Length L, mm	Width B, mm		Guides	Distance between guides, mm
	550			
	Model	Price, €		
415	Z-CFG-42/55/87	180	4 pairs	145



High-quality materials and sturdy welded construction makes the bar solutions durable and long lasting.



Hygienic design as well as welding and polishing for every unit or accessory.



Appealing and sophisticated looks allow our equipment to be installed in open-plan drink serving areas visible to customers.



Short lead times.

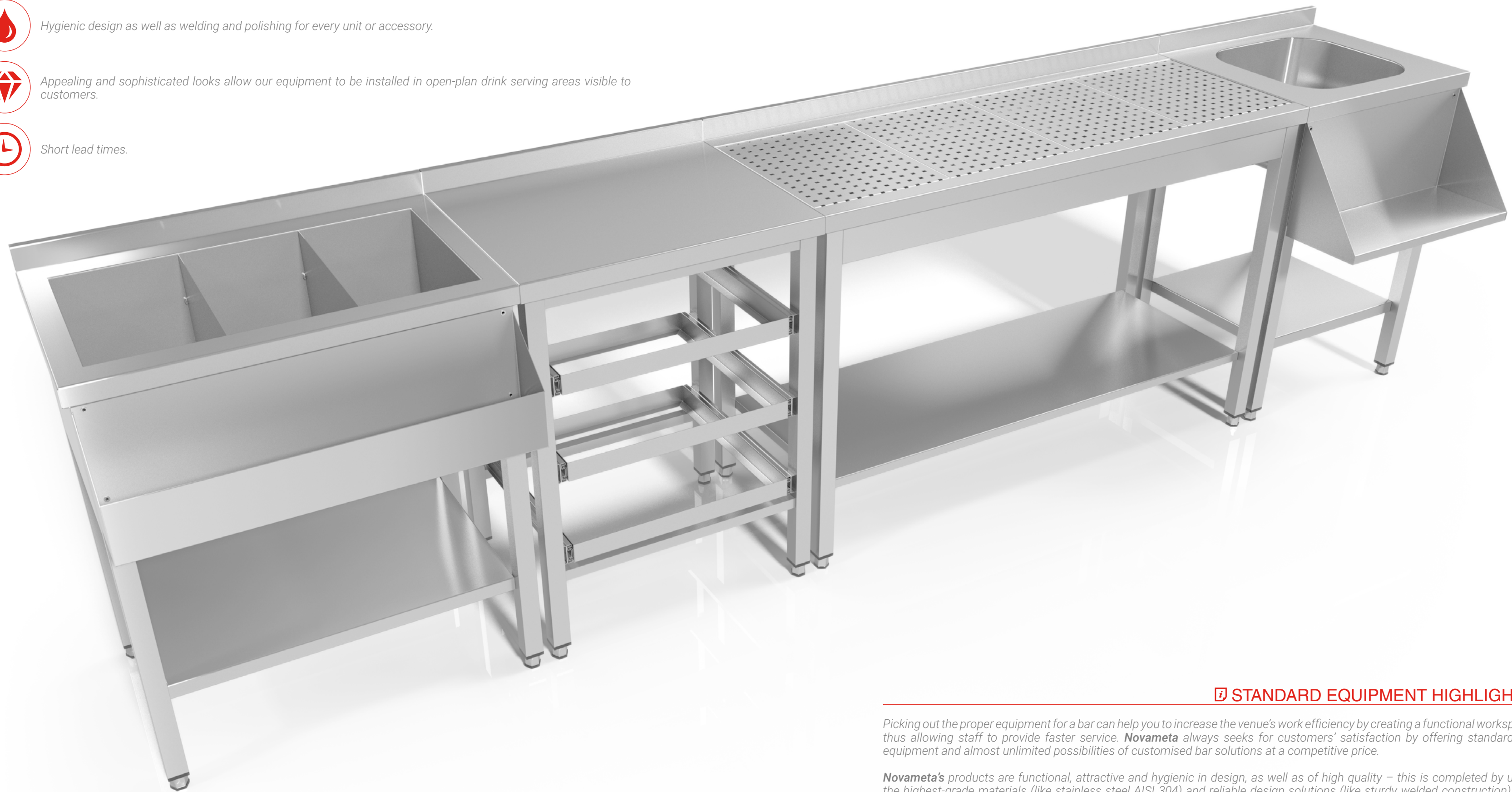

### STANDARD EQUIPMENT HIGHLIGHTS

Picking out the proper equipment for a bar can help you to increase the venue's work efficiency by creating a functional workspace, thus allowing staff to provide faster service. **Novameta** always seeks for customers' satisfaction by offering standard bar equipment and almost unlimited possibilities of customised bar solutions at a competitive price.

**Novameta's** products are functional, attractive and hygienic in design, as well as of high quality – this is completed by using the highest-grade materials (like stainless steel AISI 304) and reliable design solutions (like sturdy welded construction). Bar equipment by **Novameta** has been increasingly used around Europe in venues like bars, pubs, restaurants, hotels, coffee shops, juice bars and many more.

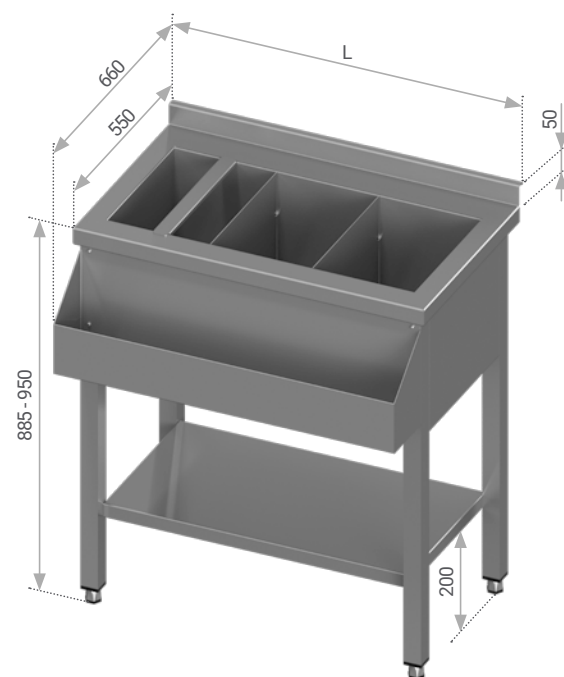

*Information icon* Different dimensions and configurations are available on request. Examples on page 7.38.

Length L, mm	Width B, mm		Price, €
	550		
	Model		
600	Z-BLL-60/55/90		1010
800	Z-BLL-80/55/90		1120
1000	Z-BLL-100/55/90		1227

**STANDARD FEATURES**

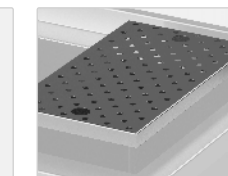
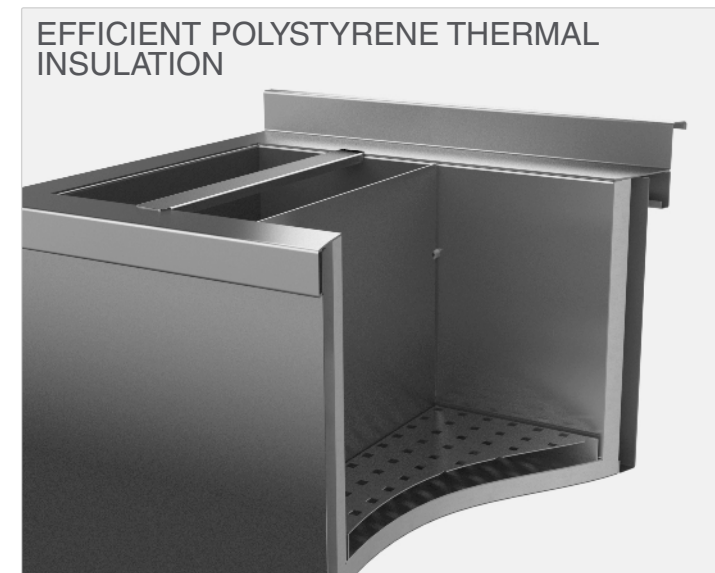

Removable drainboard (height: 20 mm)

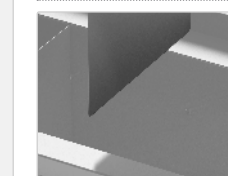

Removable partitions



Water outlet connection in the centre (external thread G1/2)

TABLE WITH DRAINBOARD

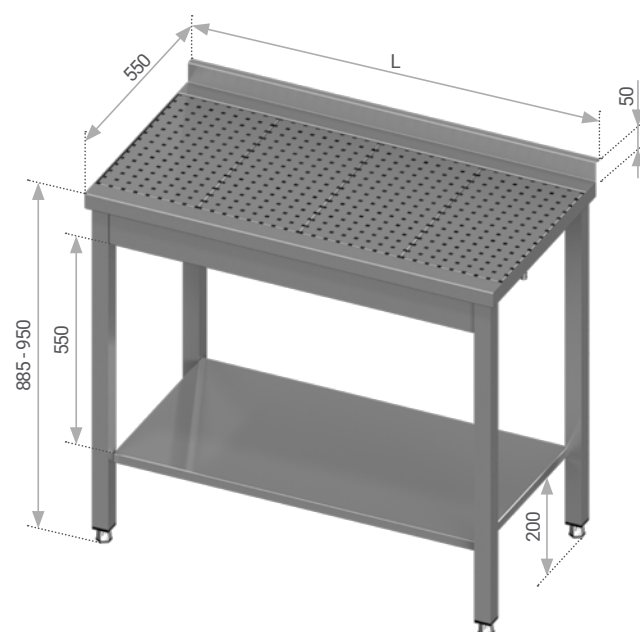

*Information icon* Different dimensions and configurations are available on request. Examples on page 7.38.

Length L, mm	Width B, mm		Price, €
	550		
	Model		
600	Z-BVL-60/55/90		442
700	Z-BVL-70/55/90		450
800	Z-BVL-80/55/90		458
900	Z-BVL-90/55/90		467
1000	Z-BVL-100/55/90		475

**STANDARD FEATURES**

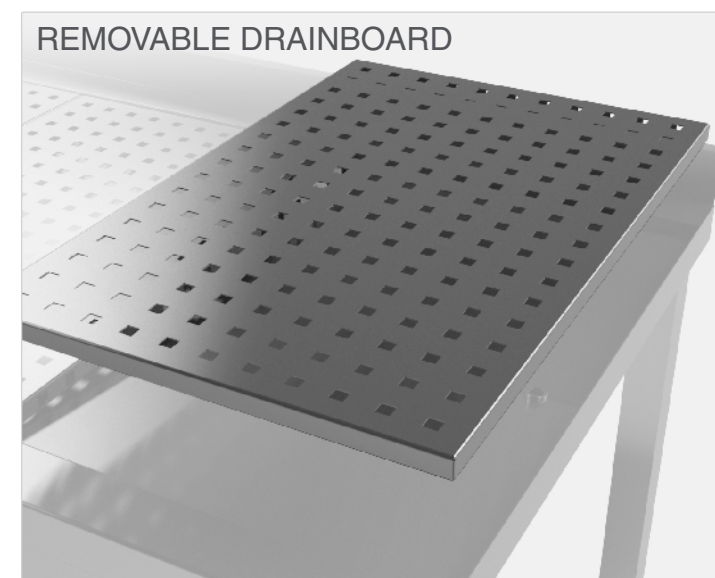

Adjustable stainless steel feet (amplitude 65 mm +50/-15)

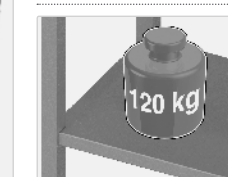

Legs made of stainless steel tube 40 x 40 mm  
Max loading 120 kg/shelf (uniform layout)



Water outlet connection in the centre (external thread G1/2)

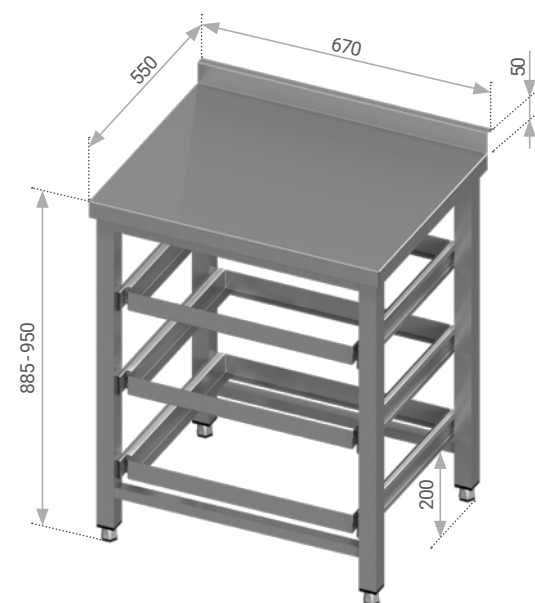

*Information icon* Different dimensions and configurations are available on request. Examples on page 7.38.

Length L, mm	Width B, mm		Model	Price, €
	550			
670	Z-BSR-67/55/90			466

**STANDARD FEATURES**



Adjustable stainless steel feet (amplitude 65 mm +50/-15)

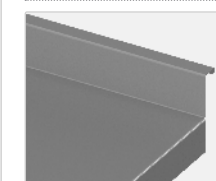

With or without upstand (all options on page 7.32)



Designed for dishwasher baskets 500 x 500 mm

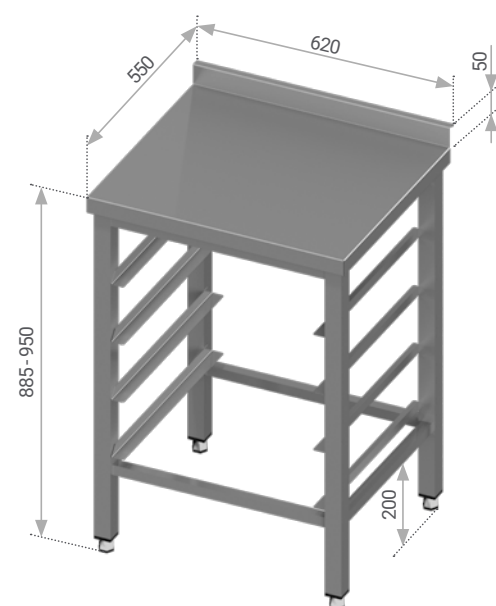

*Information icon* Different dimensions and configurations are available on request. Examples on page 7.38.

Length L, mm	Width B, mm		Guides	Distance between guides, mm	Price, €
	550				
620	Z-BKR-62/55/90		4 pairs	145	295

**STANDARD FEATURES**

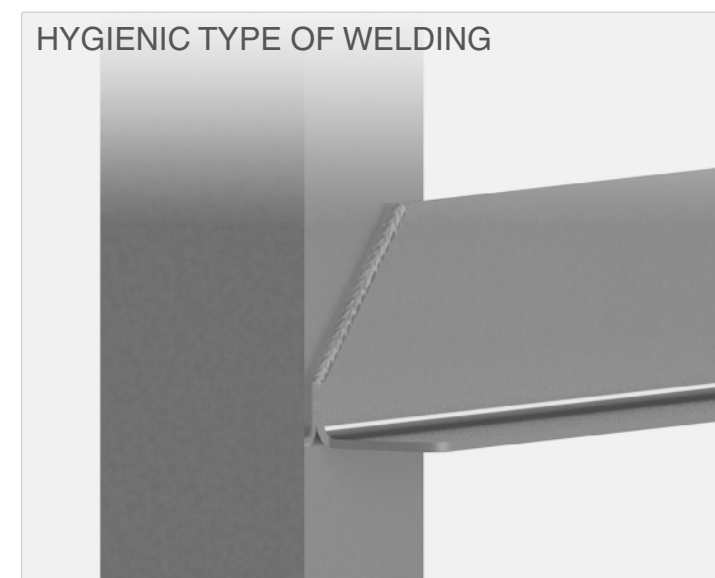

Adjustable stainless steel feet (amplitude 65 mm +50/-15)

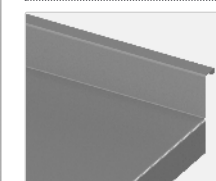

With or without upstand (all options on page 7.32)



Designed for dishwasher baskets 500 x 500 mm

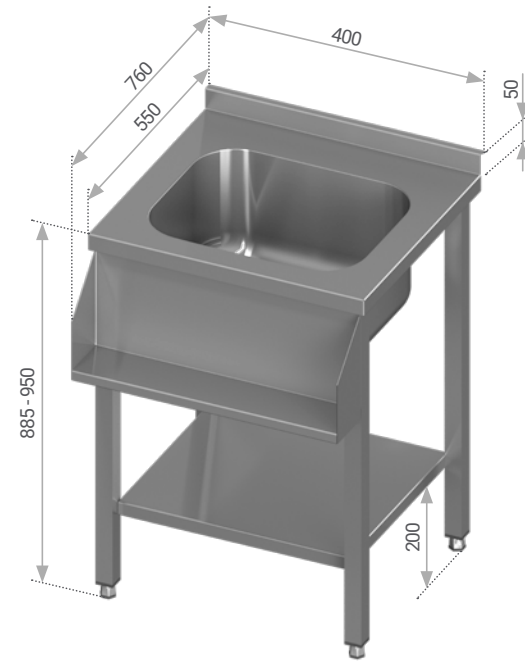

*Information icon* Different dimensions and configurations are available on request. Examples on page 7.38.

Length L, mm	Width B, mm		Model	Price, €
	550			
400	Z-BBL-40/55/90			473

**STANDARD FEATURES**

FRONT SHELF FOR BLENDER

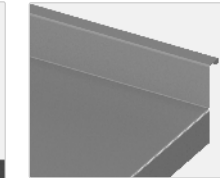
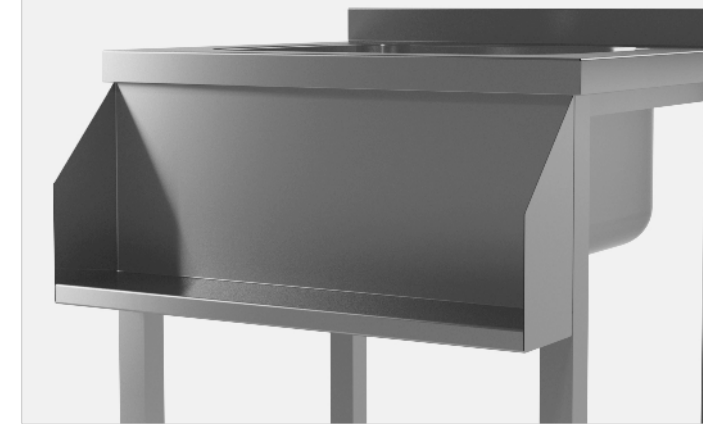

With or without upstand (all options on page 7.32)

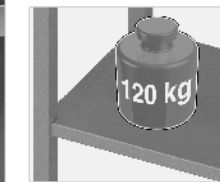

Legs made of stainless steel tube 40 x 40 mm  
Max loading 120 kg/shelf (uniform layout)



Sink 330 x 330 x 200 mm

DRAWER FOR COFFEE GRINDER

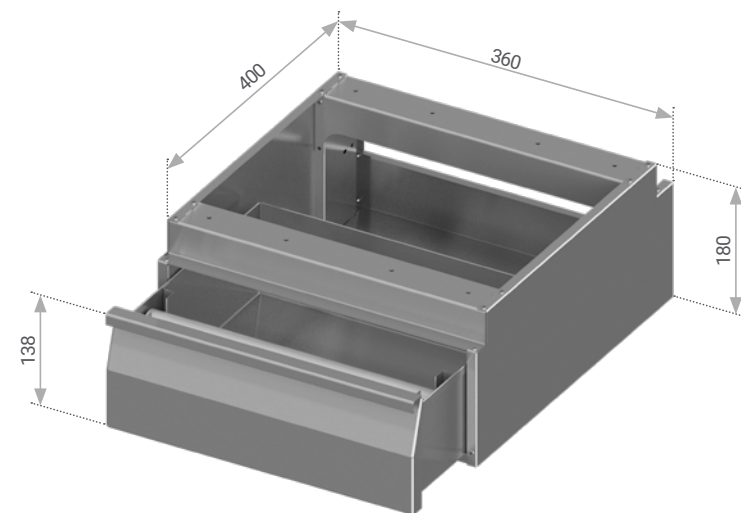

*Information icon* Different dimensions and configurations are available on request. Examples on page 7.38.

Length L, mm	Width B, mm		Model	Price, €
	400			
360	Z-Y-SKT-36/40/18			179

**STANDARD FEATURES**

RUBBER COATED KNOCK-OUT BAR

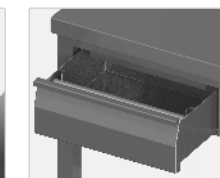
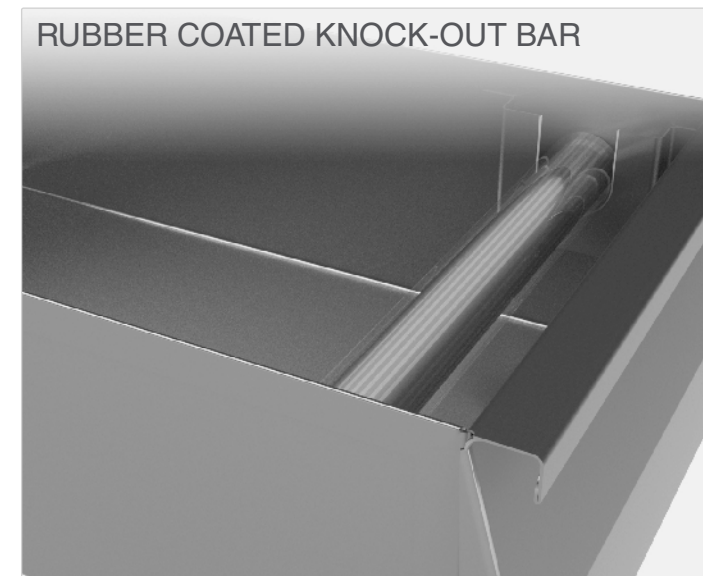





Drawer for coffee grinder mounted under table top

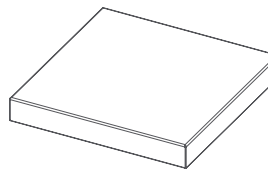
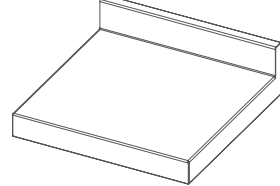
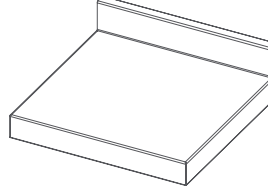
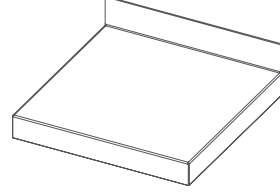
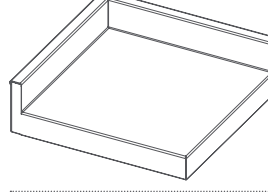
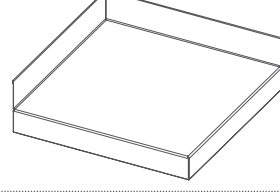
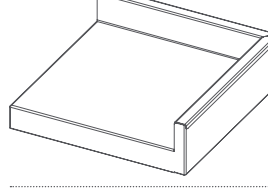
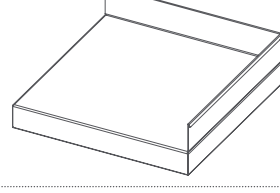
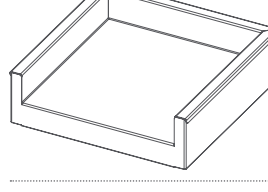
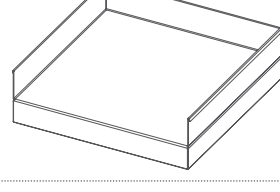
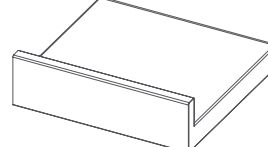



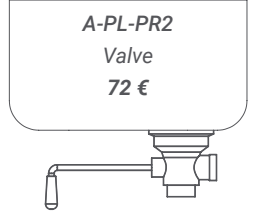

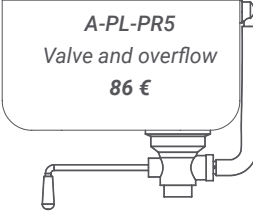
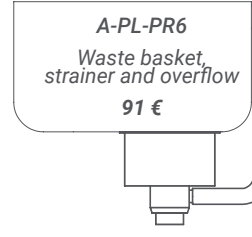
**UPSTANDS**

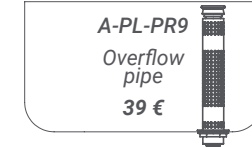
 <p><b>Without upstand</b> Code: A-DSB-1 Price: Free of charge</p>	 <p><b>Standard upstand with closed side</b> Code: A-DSB-UPK (left) A-DSB-UPD (right) Price/pc: 11 €</p>
 <p><b>Standard upstand</b> Code: A-DSB-2 Price: Free of charge</p>	 <p><b>Flat upstand</b> Code: A-DSB-3 Price: Free of charge</p>
 <p><b>Standard upstand on rear and left side</b> Code: A-DSB-4 Price: 58 €</p>	 <p><b>Flat upstand on rear and left side</b> Code: A-DSB-10 Price: 15 €</p>
 <p><b>Standard upstand on rear and right side</b> Code: A-DSB-5 Price: 58 €</p>	 <p><b>Flat upstand on rear and right side</b> Code: A-DSB-11 Price: 15 €</p>
 <p><b>Standard upstand on rear and both sides</b> Code: A-DSB-6 Price: 116 €</p>	 <p><b>Flat upstand on rear and both sides</b> Code: A-DSB-12 Price: 30 €</p>
 <p><b>Standard upstand with closed back</b> Code: A-DSB-GUJ Price: 58 €</p>	

**PLUMBING SETS**

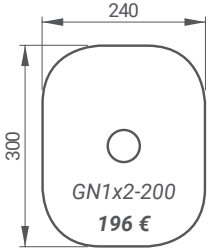
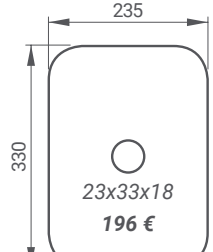
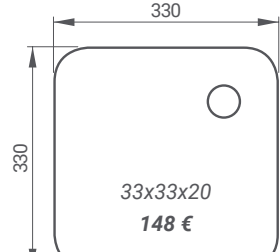
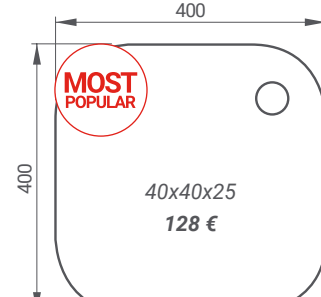
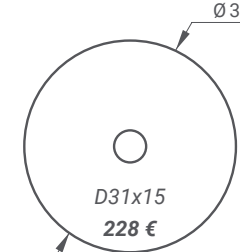
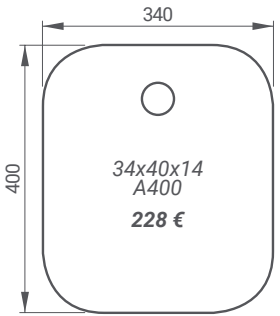
 <p><b>A-PL-PR1</b> Strainer 10 €</p>	 <p><b>A-PL-PR2</b> Valve 72 €</p>	 <p><b>A-PL-PR3</b> Waste basket with strainer 77 €</p>	 <p><b>A-PL-PR4</b> Strainer and overflow 14 €</p>	 <p><b>A-PL-PR5</b> Valve and overflow 86 €</p>
 <p><b>A-PL-PR6</b> Waste basket, strainer and overflow 91 €</p>	 <p><b>A-PL-PR7</b> Waste basket and valve 149 €</p>	 <p><b>A-PL-PR8</b> Waste basket, valve and overflow 163 €</p>	 <p><b>A-PL-PR9</b> Overflow pipe 39 €</p>	

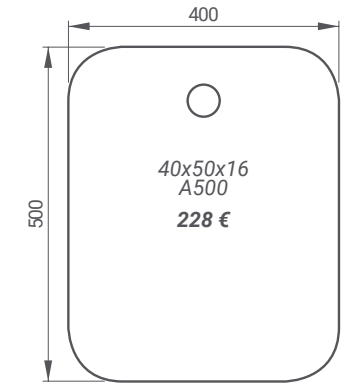
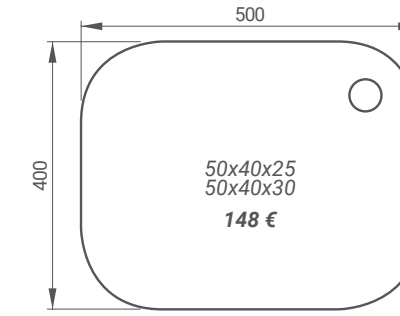
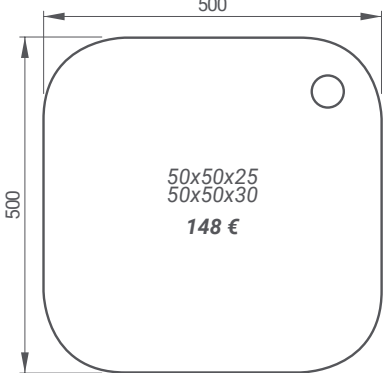
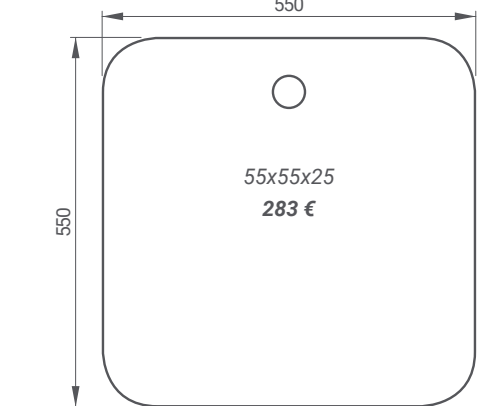
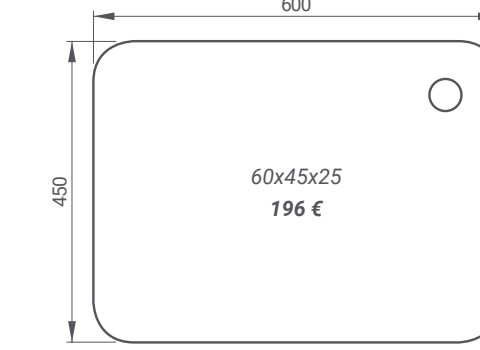
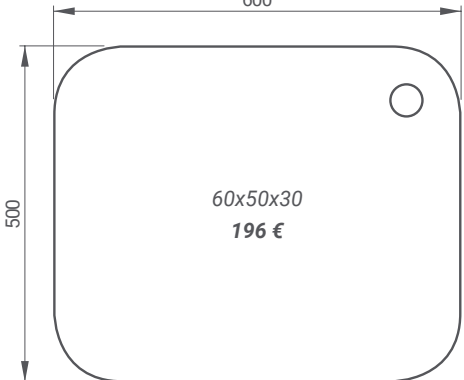
**SINKS**

 <p>240 300 GN1x2-200 196 €</p>	 <p>235 330 23x33x18 196 €</p>	 <p>330 330 33x33x20 148 €</p>	 <p>400 400 <b>MOST POPULAR</b> 40x40x25 128 €</p>	 <p>Ø 313 D31x15 228 €</p>
 <p>340 400 34x40x14 A400 228 €</p>	 <p>305 509 30x51x21 (GN compatible) 196 €</p>	 <p>400 500 40x50x16 A500 228 €</p>	 <p>500 400 50x40x25 50x40x30 148 €</p>	
 <p>500 500 50x50x25 50x50x30 148 €</p>	 <p>550 550 55x55x25 283 €</p>	 <p>600 450 60x45x25 196 €</p>		
 <p>600 500 60x50x30 196 €</p>	 <p>700 496 70x50x30 283 €</p>			

 Custom sizes are also available

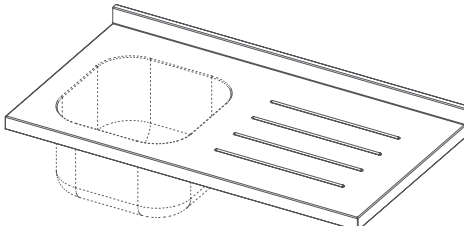
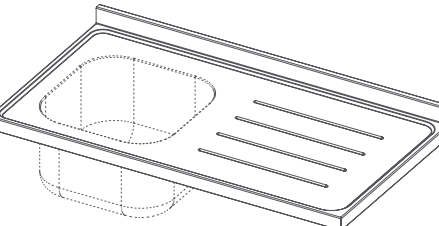
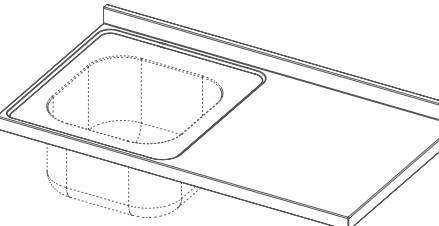
 <p><b>Z-DP-RIBS</b> Drainboard with ribbing Ask for price</p>	 <p><b>Z-DG-RIBS</b> Deepened drainboard with ribbing Ask for price</p>	 <p><b>Z-DG-PART</b> Partially deepened table top Ask for price</p>
---	--	--

**DRAWERS**

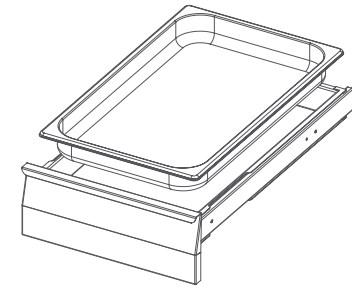

Y-SGN (for GN 1/1, containers are not included)

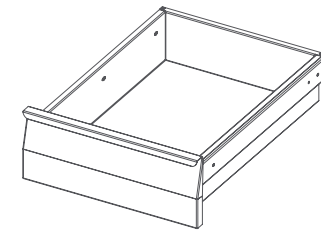

Y-STP (plain)

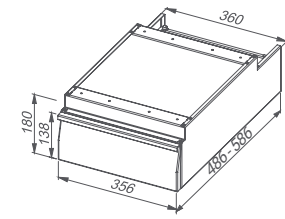

**Single drawer:**  
plain/frame for GN 1/1 container

Code: Y-STP1/Y-SGN1  
Price: 169 €

**Single drawer with closed back:**  
plain/frame for GN 1/1 container

Code: Y-STPU1/Y-SGNUM1  
Price: 202 €

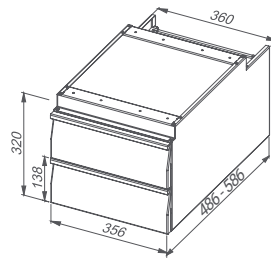

**Double drawer block:**  
plain/frame for GN 1/1 container

Code: Y-STP2/Y-SGN2  
Price: 285 €

**Double drawer block with closed back:**  
plain/frame for GN 1/1 container

Code: Y-STPU2/Y-SGNUM2  
Price: 318 €

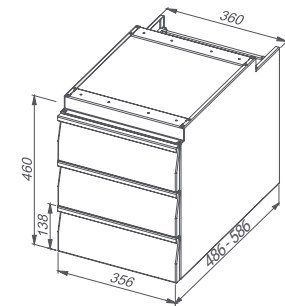

**Triple drawer block:**  
plain/frame for GN 1/1 container

Code: Y-STP3/Y-SGN3  
Price: 402 €

**Triple drawer block with closed back:**  
plain/frame for GN 1/1 container

Code: Y-STPU3/Y-SGNUM3  
Price: 435 €

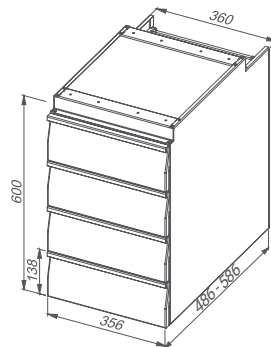

**Quadruple drawer block:**  
plain/frame for GN 1/1 container

Code: Y-STP4/Y-SGN4  
Price: 518 €

**Quadruple drawer block with closed back:**  
plain/frame for GN 1/1 container

Code: Y-STPU4/Y-SGNUM4  
Price: 551 €

## **i** NOVAMETA STANDARD TERMS

### **Applicability**

These Standard Terms ("Terms") apply to all products supplied directly by Novameta to its distributors.

### **Validity of quotations**

Quotations are valid for 90 days unless otherwise explicitly stated in the individual quotation. Not responsible for misprints.

### **Delivery terms**

Provided in the proforma invoice.

In case of ex-works (INCOTERMS 2010) Novameta shall not be liable for delays and the distributor shall not be permitted to terminate the purchase due to delays unless agreed to in writing.

### **Payment terms**

Provided in the proforma invoice.

If a higher credit limit is necessary, security is mandatory. Novameta may reduce a credit limit at any time if considered appropriate by Novameta.

### **Storage terms**

Provided in the proforma invoice.

### **Retention of Title**

Novameta shall retain title in all products and components sold to the distributor until the distributor has paid for the products in full (including transportation and packaging costs).

### **Warranty terms**

Novameta provides a Manufacturer's warranty for all of the equipment against defects in materials and workmanship for a period of 1 year from the date of invoicing of the defective product or component to the distributor. Manufacturer undertakes to replace all inferior parts to proper quality parts or materials. In case of a fault, a properly filled claim is required and must contain all essential information relative to the fault. Faulty parts shall be returned to Manufacturer for further inspection.

### **Extended warranty**

The extended warranty is solely applicable to certain equipment (indicated in the price list). The extended warranty costs extra of the item's list price. Standard warranty terms apply.

### **Warranty exclusions and limitations of liability**

The warranty in these Terms shall be the distributor's exclusive remedy for defective products and components towards Novameta. Novameta shall not be liable for any costs, expenses, losses or claims (whether direct, indirect, consequential or otherwise) relating to defective products or components unless otherwise explicitly stated herein or agreed in writing. Any expenses in connection with the installation or costs of making adjustments (including service procedures, travel time costs) on the equipment to comply with the supply at the point of installation are not covered by this warranty.

The producer does not take any responsibility for damages that occur due to ignorance of cautions, improper maintenance or mechanical damages of the unit, including those, caused during the delivery. This warranty is not effective if damage occurs from improper installation, misuse; incorrect voltage supply, wear and tear from normal usage, accidental breakage, damage or if the equipment is operated contrary to the user instructions. The warranty does not cover if the damage occurs due to natural disasters; fire, if repair service was made by unauthorized person.

In case of a failure not covered by the warranty, we provide a possibility to purchase spare parts.

## **i** NOVAMETA STANDARD TERMS

### **Procedure for repair or replacement under the warranty**

The distributor shall, at its own costs, make all reasonable attempts to repair any defective component or product.

If such repair is not possible for the distributor, the distributor shall contact Novameta in writing immediately (within 3 working days) upon suspicion of any defects that may be covered by the warranty. If Novameta is not contacted immediately (within 3 working days) in such cases, the distributor shall have no remedies.

Distributor's contact shall include specific information as to the suspected defect the relevant order number and a copy of the relevant invoice.

After timely receipt of the above, Novameta will decide if there is a defect, whether the claim is covered by the warranty, and whether the product or component is to be replaced.

In cases where Novameta decides to replace defective products or components with new ones, the distributor will be billed the full amount for the goods when they are sent. This amount will then be credited when the defective product or components is returned to Novameta and it is established that the defective product or component is covered by the warranty.

With regard to the transport of products and components, Novameta will pay the freight of new or repaired products and components, while the distributor will pay the freight for defective goods that are returned (and any other costs related to the return of the goods). The warranty does not cover expenses of the service procedures performed. Novameta does not provide service.

Unless otherwise agreed in writing, the defective product or component should always be returned to Novameta: Draugystės g. 15D, LT-51227 Kaunas, Lithuania.

### **Cancellations**

If an order cancellation request is made after confirmation of drawing and proforma invoice, adjustments are not possible and production cannot be stopped. In case of cancellation product will be charged in full.

### **Shipping and packing**

Novameta will pack products for shipment in Novameta standard packaging. If the distributor has other requirements as to packing, the distributor shall contact Novameta to make special arrangements.

### **Delivery recommendations**

Upon receipt, inspect units immediately for any shipping damage and notify carrier immediately if damage is found. It must be reported immediately (upon delivery) in writing in the CMR. Otherwise neither the Manufacturer nor the carrier can take responsibility for transport damage. All items are thoroughly inspected and carefully packed before leaving our factory, thus Novameta cannot accept responsibility for any shipping damage, however Novameta will assist in filing a claim.

### **Liability and Product liability**

Novameta shall only be liable for defects and product liability to the extent set out herein (see particularly warranty terms). In addition to the aforesaid all liability is capped at the invoiced price of the defective product. All other liability is hereby excluded.

### **Choice of law and Venue**

These Terms and the cooperation between Novameta and its distributors, including any disputes relating thereto, shall be governed by Lithuanian law.

Any disputes shall be settled before the Lithuanian courts, which shall have exclusive jurisdiction.

Company No. 235886490, VAT Reg. No. LT 358864917

Reg. No. 048959, Centre of Registers

IBAN: LT227300010071982293, Swedbank, AB

**REFERENCES**

**HOTELS**

*Copenhagen Marriott Hotel*  
Copenhagen, Denmark

*Highland Lodge Hotel*  
Gelo, Norway

*Kempinski Hotel Cathedral Square*  
Vilnius, Lithuania

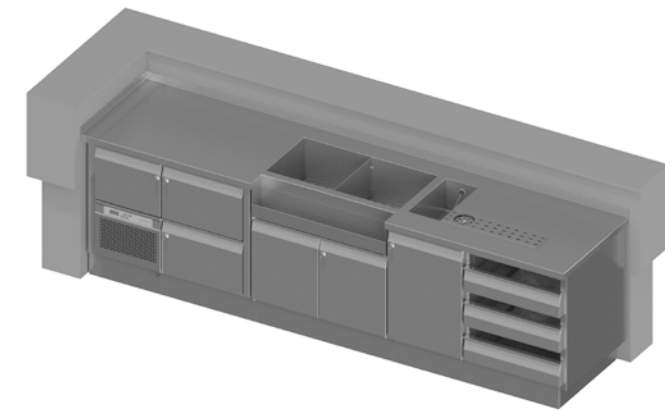

XKA16-1026

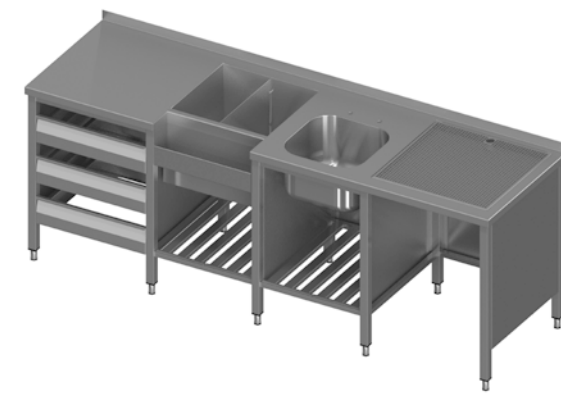

ZD17-7003

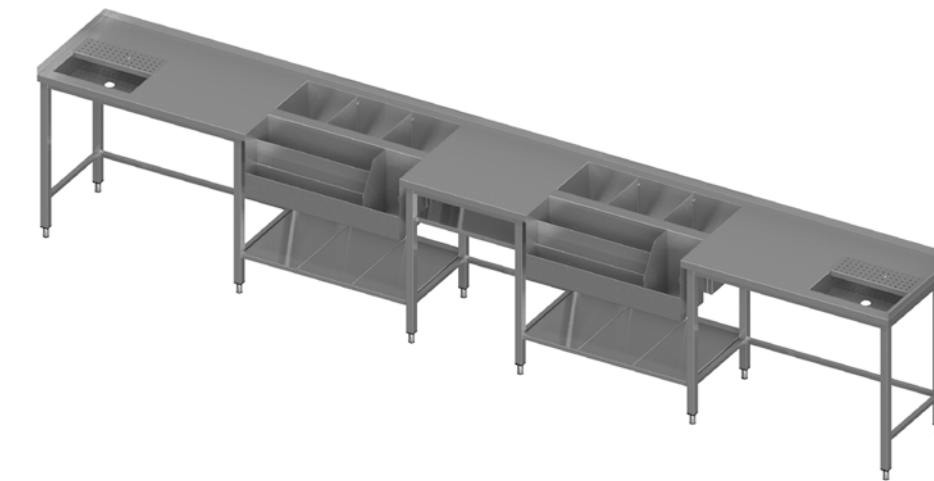

ZA15-1083

**RESTAURANTS AND BARS**

*Bierhuis Restaurant*  
Uppsala, Sweden

*Chateau Motel Nightclub*  
Copenhagen, Denmark

*Rockabilly House Restaurant*  
Riga, Latvia

*Salt & Pepper Restaurant*  
Hønefoss, Norway

*Bar Babylon*  
Oslo, Norway

*Åhléns Department Store*  
Stockholm, Sweden

*Copenhagen Towers*  
Copenhagen, Denmark

*Downtown*  
Trondheim, Norway

*Annabels Bar & Restaurant*  
Uppsala, Sweden

*Copenhagen Business School*  
Copenhagen, Denmark

*The Well Spa Centre*  
Oslo, Norway

*Shikary Restaurant*  
Minsk, Belarus

*Gå Nord Restaurant*  
Antwerp, Belgium

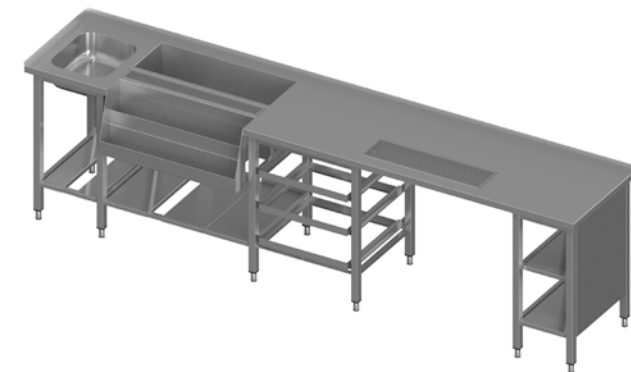

ZA16-1069

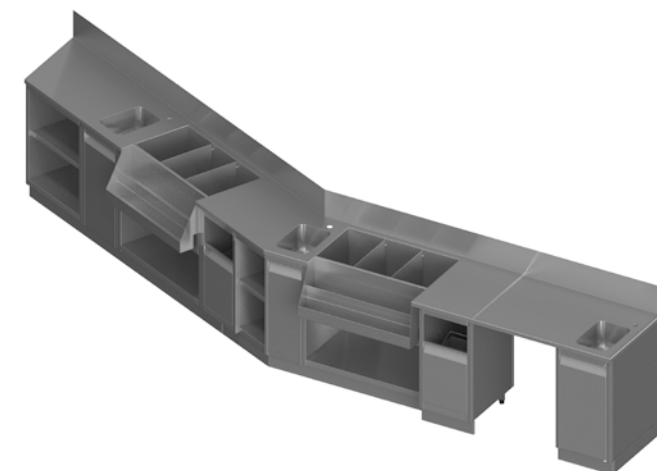

ZQ16-7008

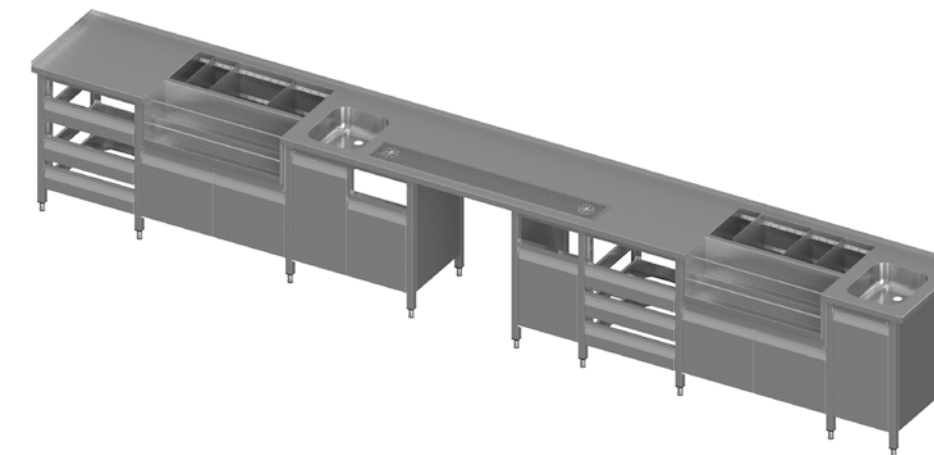

ZA16-7004

**LARGE VENUES**

*Žalgiris Arena*  
Kaunas, Lithuania

*Ullevaal Stadion*  
Oslo, Norway



ZU16-1312

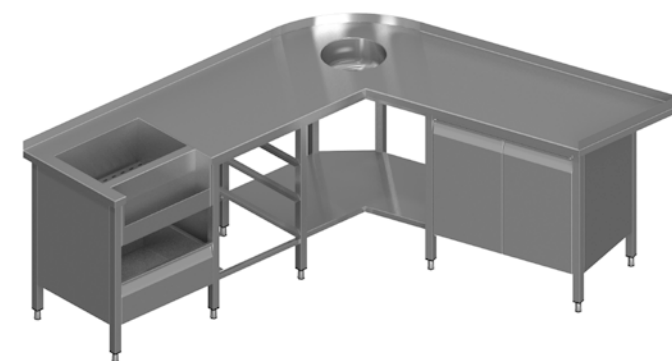

ZA16-7023

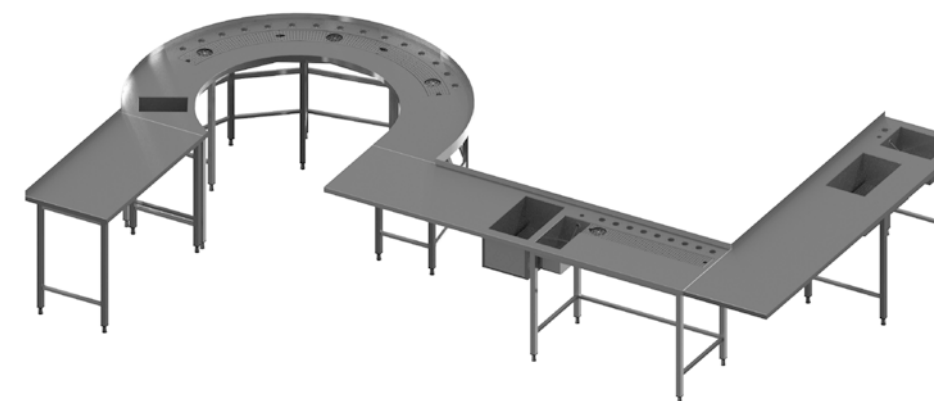

ZA16-7013

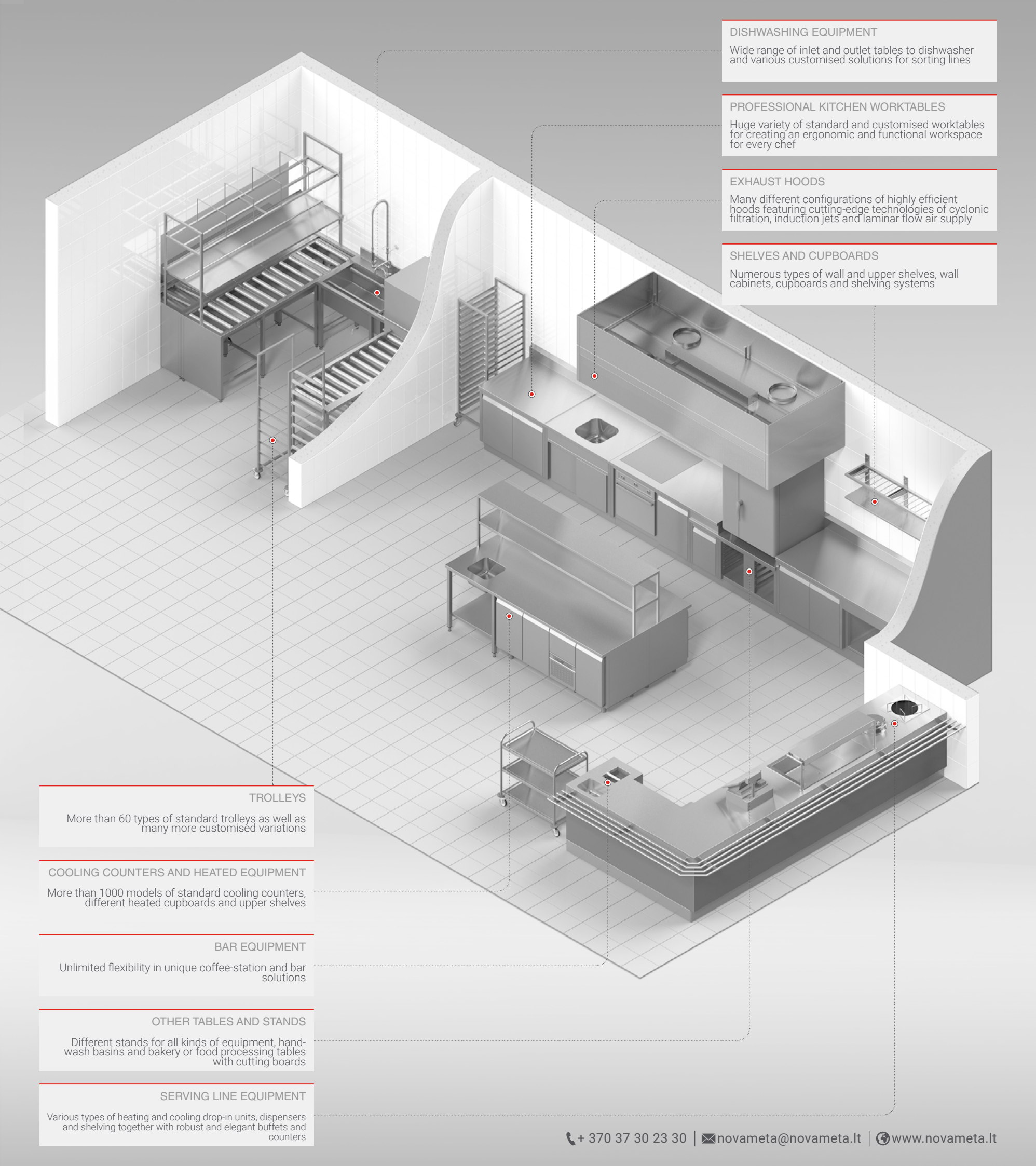

#### DISHWASHING EQUIPMENT

Wide range of inlet and outlet tables to dishwasher and various customised solutions for sorting lines

#### PROFESSIONAL KITCHEN WORKTABLES

Huge variety of standard and customised worktables for creating an ergonomic and functional workspace for every chef

#### EXHAUST HOODS

Many different configurations of highly efficient hoods featuring cutting-edge technologies of cyclonic filtration, induction jets and laminar flow air supply

#### SHELVES AND CUPBOARDS

Numerous types of wall and upper shelves, wall cabinets, cupboards and shelving systems

#### TROLLEYS

More than 60 types of standard trolleys as well as many more customised variations

#### COOLING COUNTERS AND HEATED EQUIPMENT

More than 1000 models of standard cooling counters, different heated cupboards and upper shelves

#### BAR EQUIPMENT

Unlimited flexibility in unique coffee-station and bar solutions

#### OTHER TABLES AND STANDS

Different stands for all kinds of equipment, hand-wash basins and bakery or food processing tables with cutting boards

#### SERVING LINE EQUIPMENT

Various types of heating and cooling drop-in units, dispensers and shelving together with robust and elegant buffets and counters