

PRICE LIST 2017

1. PROFESSIONAL KITCHEN WORKTABLES
2. OTHER TABLES AND STANDS
3. DISHWASHING EQUIPMENT
4. SHELVES AND CUPBOARDS
5. TROLLEYS
6. EXHAUST HOODS
7. BAR EQUIPMENT
8. SERVING LINE EQUIPMENT
9. COOLING COUNTERS AND HEATED EQUIPMENT
10. MODULAR TABLES

YOUR RELIABLE PARTNER

Novameta is the largest and most advanced manufacturer of stainless steel commercial kitchen equipment in Baltic and Scandinavian countries. Extensive 16-year experience, attention to details along with an innovative mindset are the key factors which have enabled **Novameta** to establish trust in 18 markets throughout Europe.

A wide range of hot, cold and neutral standard equipment, precisely engineered and crafted non-standard products combined with a short, typically 2-4 week lead time is what makes us stand out of the crowd. What is more, our experienced team is all set to provide professional support and technical advice, enabling our clients to turn their ideas to tailor made turnkey solutions.

All of our products are marketed through a professional network of distributors throughout Europe. We are proud to provide an all-round assistance to our dealers, helping them to excel in the things they do best - planning, taking care of supply, installation and service to fulfil the needs of catering, bakery and retail industries.

Our main objectives are to maintain solid positions in Europe through sustaining partnership relationships with our clients, whilst at the same time expanding into new markets worldwide. Experienced and ambitious sales team, application of up-to-date 3D CAD software in our in-house design department, employment of latest production technologies and LEAN quality management based on ISO 9001:2000 standard, have determined the rapid expansion of our sales markets and therefore the consequent quick growth of the company.

Currently, over 165 employees work in the enterprise and the production area covers 5000 m². **Novameta** manufactures over 180 different items every day, more than 1000 projects yearly!



Novameta

📍 Draugystės g. 15D, LT-51227 Kaunas, Lithuania
 ☎ +370 37 30 23 30
 ✉ novameta@novameta.lt
 🌐 www.novameta.lt

Novameta UK

📍 1210 Parkview, Arlington Business Park, Theale, Reading, Berkshire RG7 4TY, UK
 ☎ +44 118 965 4098
 📞 +44 791 874 0027
 ✉ sales@novameta.co.uk
 🌐 www.novameta.co.uk

© 2017 **Novameta**. All rights reserved.

Novameta respects the intellectual property rights of others and expects its clients and the users of its services to do the same. All information in this publication is property of **Novameta** and you do not have right to disclose it to any third party without permission. **Technical specifications and prices are subject to change.**

CONTENTS

STAND FOR DISHWASHER WITH GUIDE RAILS FOR 2 DISHWASHER BASKETS

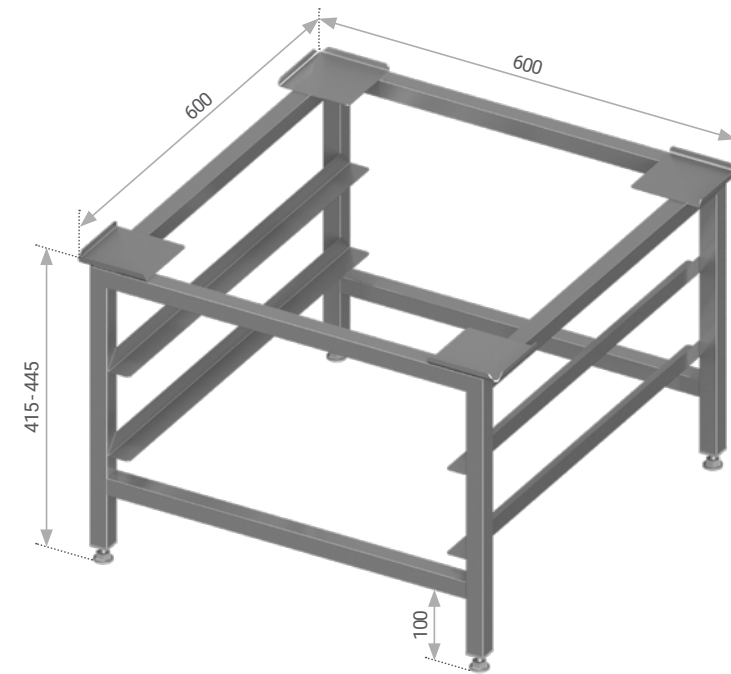

Information icon Different dimensions and configurations are available on request. Examples on page 2.38.

Length L, mm	Width B, mm		Amount of guides	Distance between guides, mm	Dimensions of basket, mm
	Model	Price, €			
600	OB2-PR0-60/60/42	176	2	120	500 x 500

STANDARD FEATURES

ANTI SLIDE CORNERS
(100 x 100 mm)

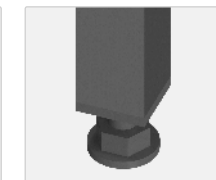
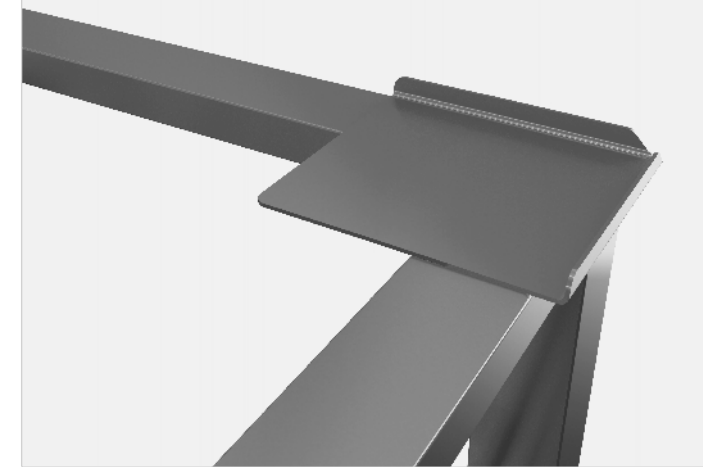

Adjustable stainless steel feet
(amplitude 30 mm +25/-5)



Welded frame
Legs made of stainless steel tube 25 x 25 mm
Frame made of stainless steel tube 25 x 25 mm

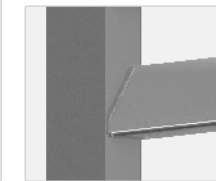

Hygienic type of welding

OPTIONAL FEATURES

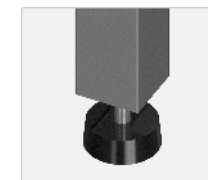

Heavy duty adjustable feet, 4 pcs.
(amplitude 40 mm, +20/-20)

Code: A-KS-M10x40
Price: 29 €

STAND FOR CONVECTION OVEN WITH GUIDE RAILS FOR 8 BAKING TRAYS

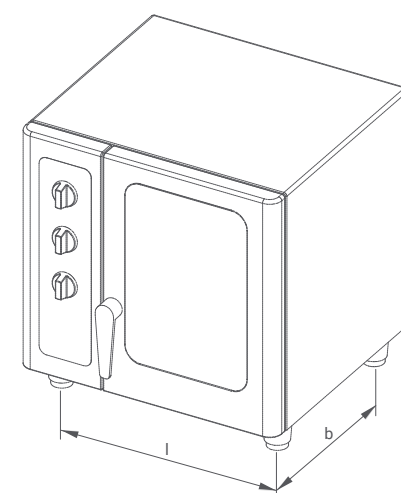
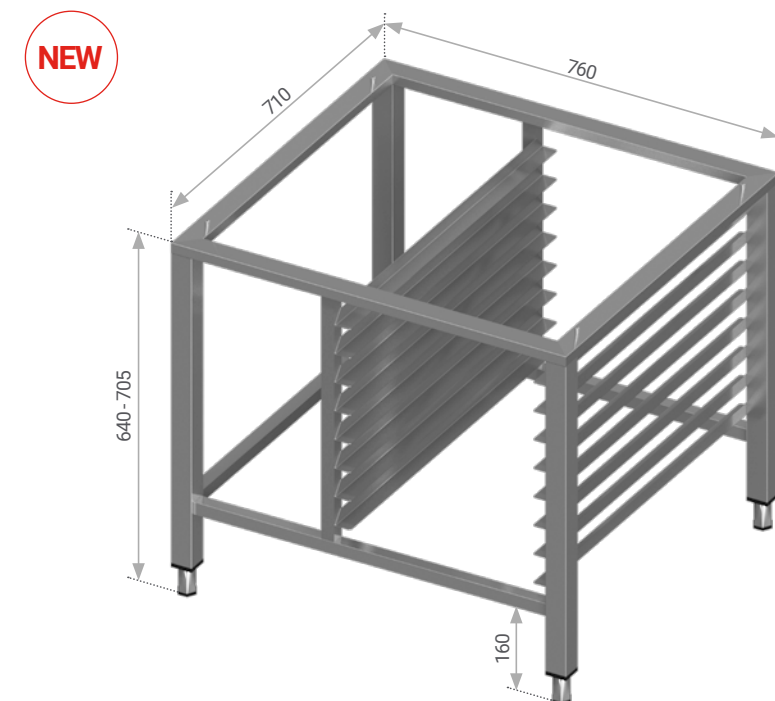

Recommended dimensions of oven:

l = 711 mm
b = 552 mm

l - distance between centre of front legs
b - distance between centre of side legs

Information icon Different dimensions and configurations are available on request. Examples on page 2.38.

Length L, mm	Width B, mm		Amount of guides	Distance between guides, mm	Size of tray, mm
	Model	Price, €			
760	OT8-SRA-76/71/68	368	8	55	Baking tray 600 x 400

STANDARD FEATURES

ANTI SLIDE PIN
(Ø 7 mm)



Adjustable stainless steel feet
(amplitude 65 mm +25/-40)

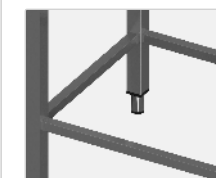

Welded frame
Legs made of stainless steel tube 40 x 40 mm
Frame made of stainless steel tube 40 x 20 and 25 x 25 mm

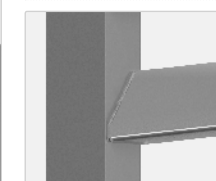

Hygienic type of welding

OPTIONAL FEATURES

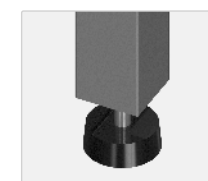

Heavy duty adjustable feet, 4 pcs.
(amplitude 40 mm, +20/-20)

Code: A-KS-M10x40
Price: 29 €

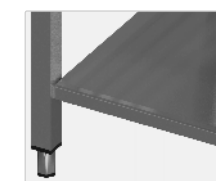

Removable shelves (2 pcs.)

Code: OT8-SRA-00.01
Price: 45 €

STAND FOR CONVECTION OVEN WITH GUIDE RAILS FOR 6 GN-1/1 TRAYS

NEW

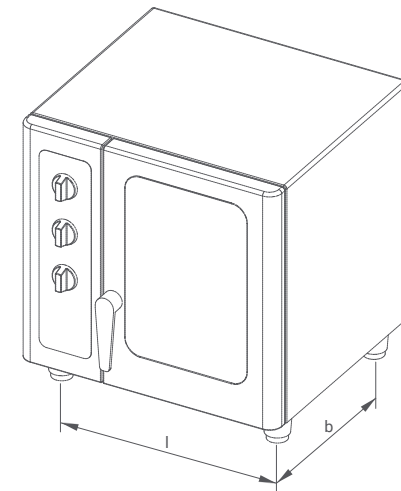
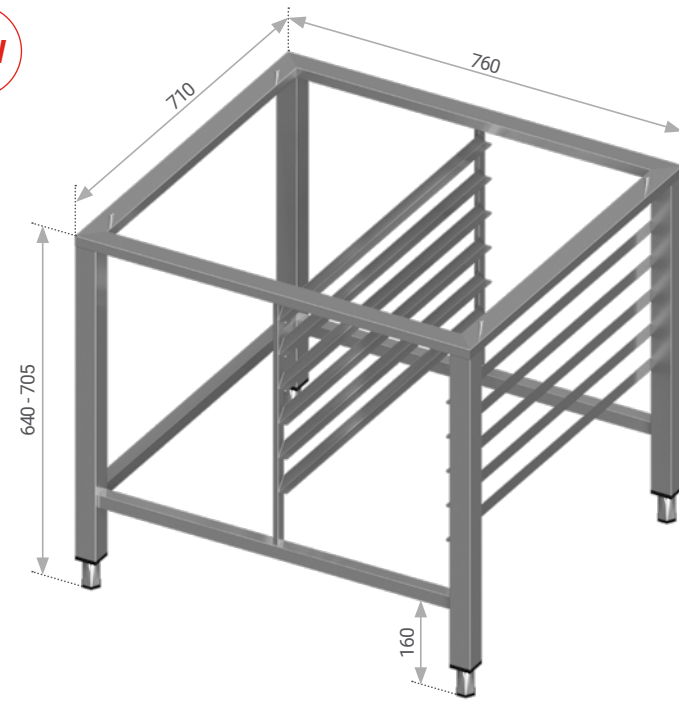

Recommended dimensions of oven:
 l = 711 mm
 b = 552 mm
 l - distance between centre of front legs
 b - distance between centre of side legs

i Different dimensions and configurations are available on request. Examples on page 2.38.

Length L, mm	Width B, mm		Amount of guides	Distance between guides, mm	Dimensions of container, mm
	Model	Price, €			
760	OG6-SRA-76/71/68	302	6	66	1/1 GN 325 x 530

STANDARD FEATURES

ANTI SLIDE PIN
 (Ø 7 mm)



Adjustable stainless steel feet
 (amplitude 65 mm +25/-40)

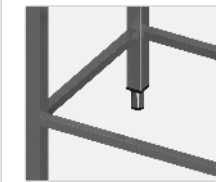

Welded frame
 Legs made of stainless steel tube 40 x 40 mm
 Frame made of stainless steel tube 40 x 20 and 25 x 25 mm

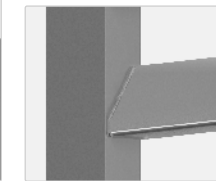

Hygienic type of welding

OPTIONAL FEATURES

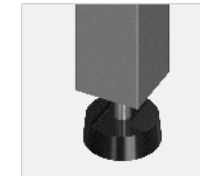

Heavy duty adjustable feet, 4 pcs.
 (amplitude 40 mm, +20/-20)
 Code: A-KS-M10x40
 Price: 29 €

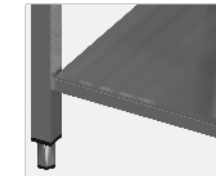

Removable shelves (2 pcs.)
 Code: OG6-SRA-00.01
 Price: 45 €

STAND FOR CONVECTION OVEN WITH GUIDE RAILS FOR 12 GN-1/1 TRAYS

NEW

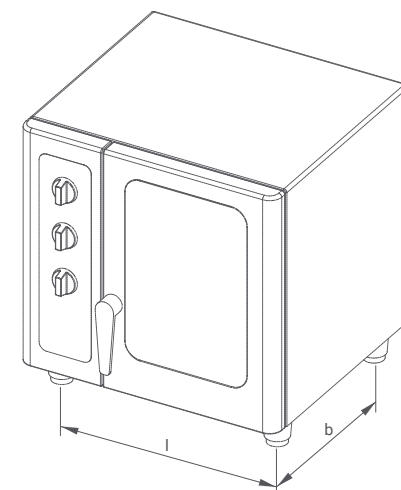
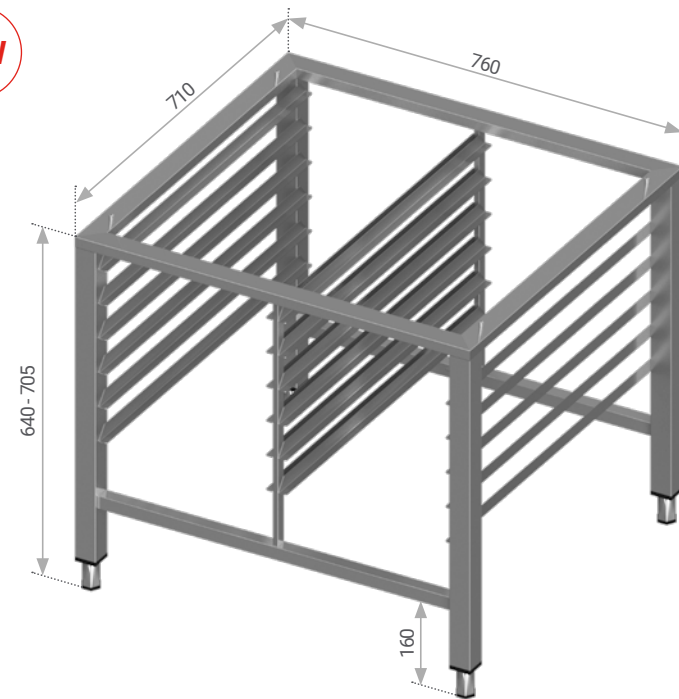

Recommended dimensions of oven:
 l = 711 mm
 b = 552 mm
 l - distance between centre of front legs
 b - distance between centre of side legs

i Different dimensions and configurations are available on request. Examples on page 2.38.

Length L, mm	Width B, mm		Amount of guides	Distance between guides, mm	Dimensions of container, mm
	Model	Price, €			
760	OG12-SRA-76/71/68	361	12	66	1/1 GN 325 x 530

STANDARD FEATURES

ANTI SLIDE PIN
 (Ø 7 mm)



Adjustable stainless steel feet
 (amplitude 65 mm +25/-40)

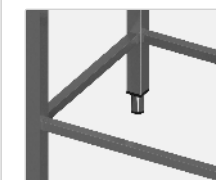

Welded frame
 Legs made of stainless steel tube 40 x 40 mm
 Frame made of stainless steel tube 40 x 20 and 25 x 25 mm



Hygienic type of welding

OPTIONAL FEATURES

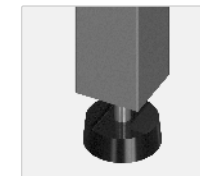

Heavy duty adjustable feet, 4 pcs.
 (amplitude 40 mm, +20/-20)
 Code: A-KS-M10x40
 Price: 29 €

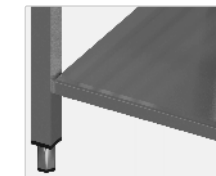

Removable shelves (2 pcs.)
 Code: OG12-SRA-00.01
 Price: 45 €

UNIVERSAL STAND FOR CONVECTION OVEN WITH GUIDE RAILS FOR 8 GN-1/1 TRAYS



NEW

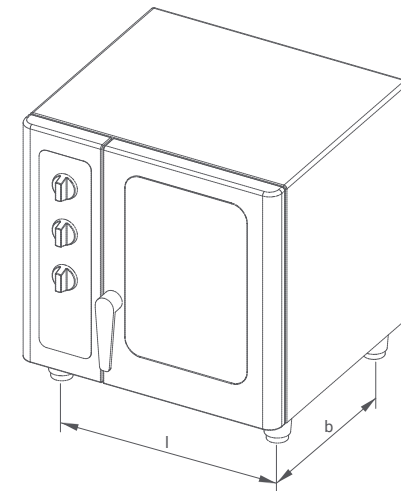
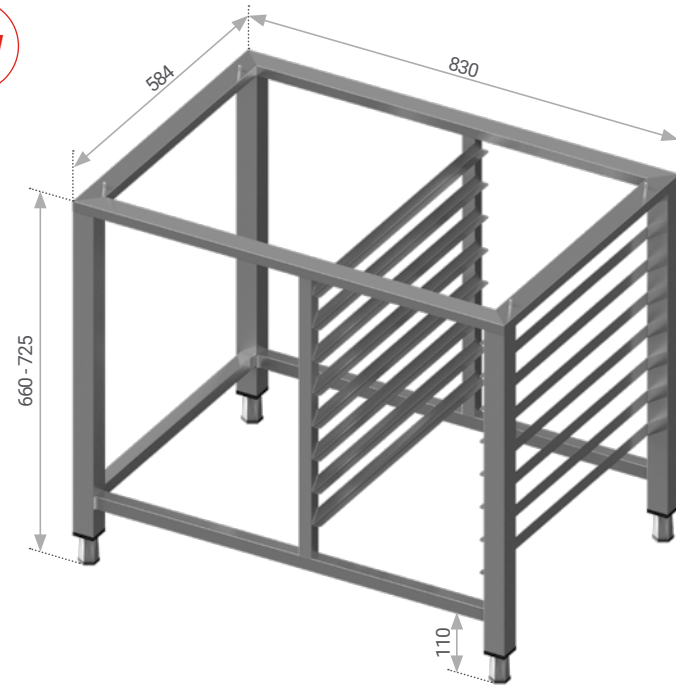

Recommended dimensions of oven:
 l = 781 mm
 b = 450 mm
 l - distance between centre of front legs
 b - distance between centre of side legs

i Different dimensions and configurations are available on request. Examples on page 2.38.

Length L, mm	Width B, mm		Amount of guides	Distance between guides, mm	Dimensions of container, mm
	Model	Price, €			
830	OG8-SRE-83/58/70	331	8	63	1/1 GN 325 x 530

STANDARD FEATURES

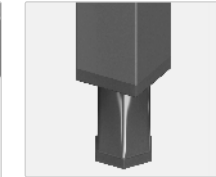

Adjustable stainless steel feet (amplitude 65 mm +25/-40)

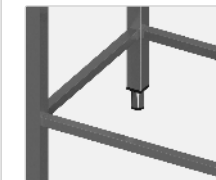

Welded frame
 Legs made of stainless steel tube 40 x 40 mm
 Frame made of stainless steel tube 40 x 20 and 25 x 25 mm

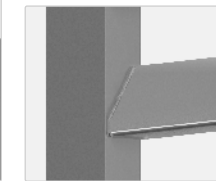

Hygienic type of welding

OPTIONAL FEATURES



Heavy duty adjustable feet, 4 pcs. (amplitude 40 mm, +20/-20)
 Code: A-KS-M10x40
 Price: 29 €

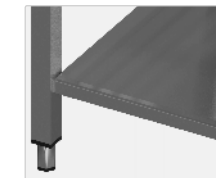

Removable shelves (2 pcs.)
 Code: OG8-SRE-00.01
 Price: 45 €

UNIVERSAL STAND FOR CONVECTION OVEN WITH GUIDE RAILS FOR 16 GN-1/1 TRAYS

NEW

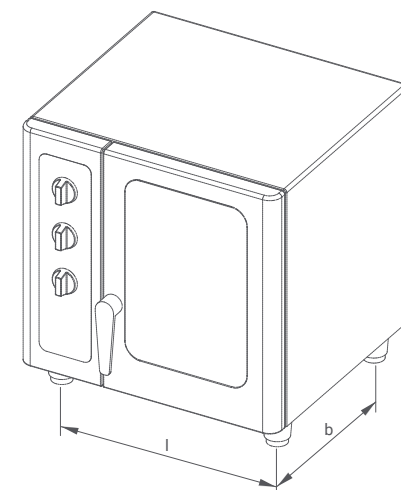
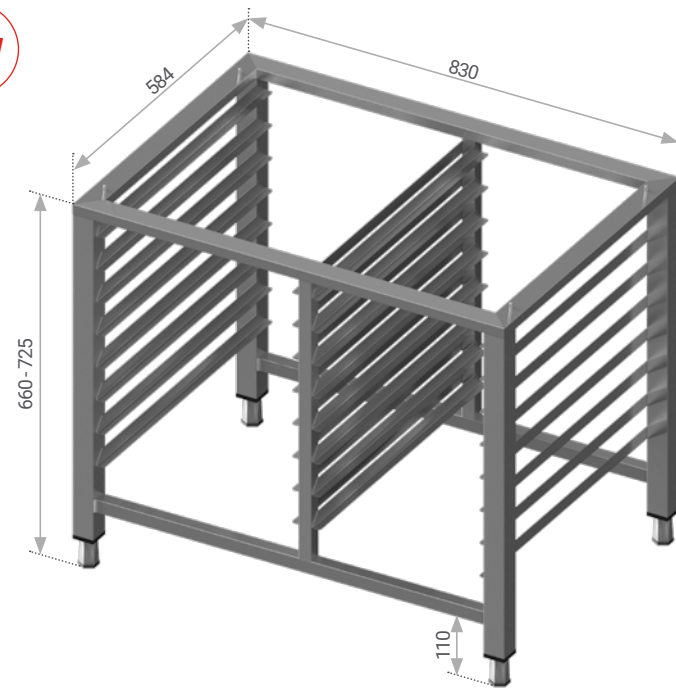

Recommended dimensions of oven:
 l = 781 mm
 b = 450 mm
 l - distance between centre of front legs
 b - distance between centre of side legs

i Different dimensions and configurations are available on request. Examples on page 2.38.

Length L, mm	Width B, mm		Amount of guides	Distance between guides, mm	Dimensions of container, mm
	Model	Price, €			
830	OG16-SRE-83/58/70	435	16	63	1/1 GN 325 x 530

STANDARD FEATURES



Adjustable stainless steel feet (amplitude 65 mm +25/-40)

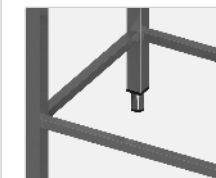

Welded frame
 Legs made of stainless steel tube 40 x 40 mm
 Frame made of stainless steel tube 40 x 20 and 25 x 25 mm

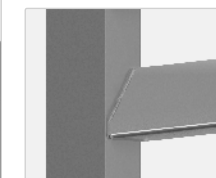

Hygienic type of welding

OPTIONAL FEATURES

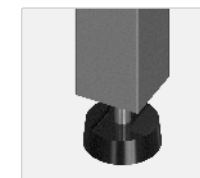

Heavy duty adjustable feet, 4 pcs. (amplitude 40 mm, +20/-20)
 Code: A-KS-M10x40
 Price: 29 €

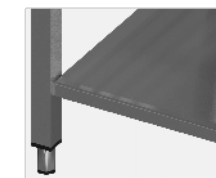

Removable shelves (2 pcs.)
 Code: OG16-SRE-00.01
 Price: 45 €

UNIVERSAL STAND FOR CONVECTION OVEN WITH GUIDE RAILS FOR 6 GN-1/1 TRAYS

NEW

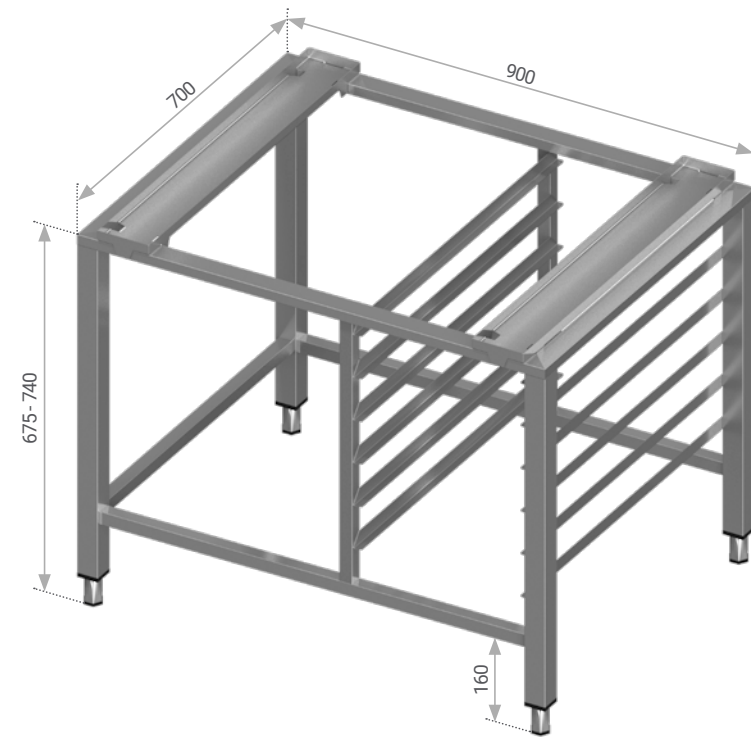

Information icon Different dimensions and configurations are available on request. Examples on page 2.38.

Length L, mm	Width B, mm		Amount of guides	Distance between guides, mm	Dimensions of container, mm
	Model	Price, €			
900	700	345	6	82	1/1 GN 325 x 530

STANDARD FEATURES

ADJUSTABLE HOLDERS
(100 x 705 mm)

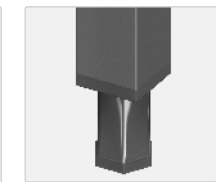
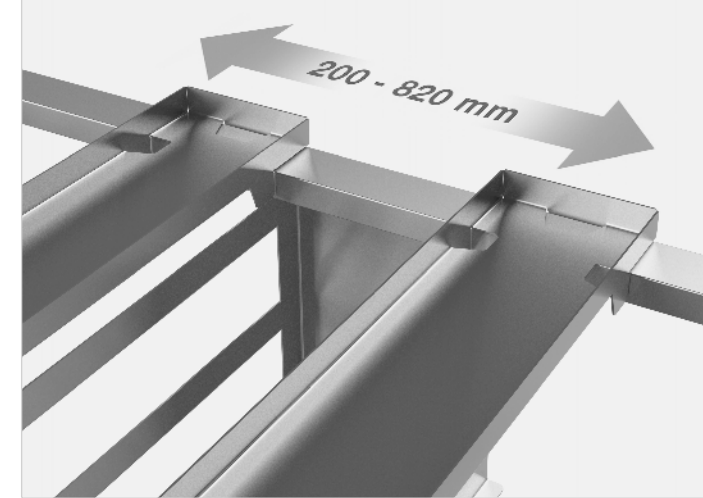

Adjustable stainless steel feet
(amplitude 65 mm +30/-35)

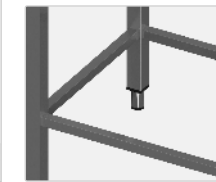

Welded frame
Legs made of stainless steel tube 40 x 40 mm
Frame made of stainless steel tube 40 x 20 and 25 x 25 mm

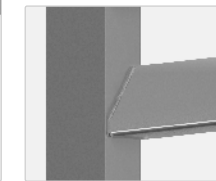

Hygienic type of welding

OPTIONAL FEATURES



Heavy duty adjustable feet, 4 pcs.
(amplitude 40 mm, +20/-20)

Code: A-KS-M10x40
Price: 29 €

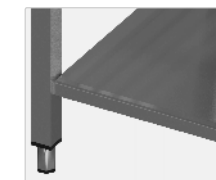

Removable shelves (2 pcs.)

Code: OG6-IRK-00.01
Price: 45 €

UNIVERSAL STAND FOR CONVECTION OVEN WITH GUIDE RAILS FOR 12 GN-1/1 TRAYS

NEW

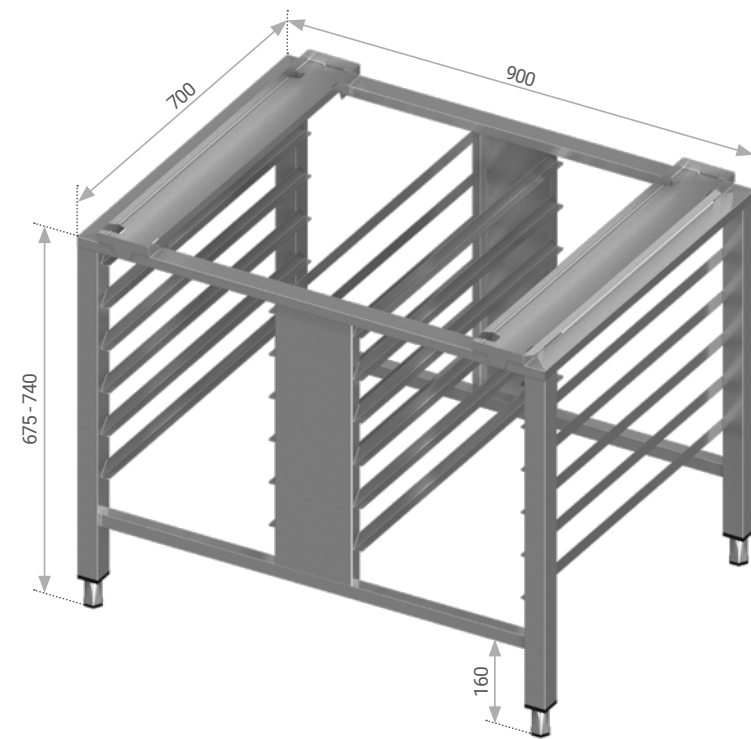

Information icon Different dimensions and configurations are available on request. Examples on page 2.38.

Length L, mm	Width B, mm		Amount of guides	Distance between guides, mm	Dimensions of container, mm
	Model	Price, €			
900	700	423	12	82	1/1 GN 325 x 530

STANDARD FEATURES

ADJUSTABLE HOLDERS
(100 x 705 mm)

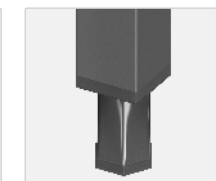
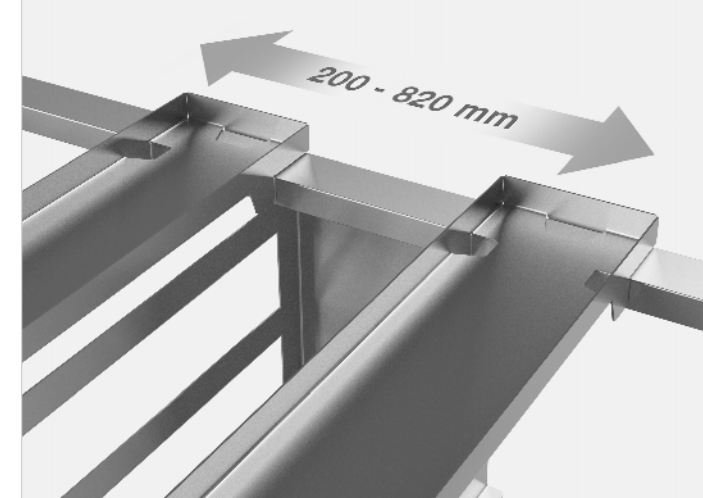

Adjustable stainless steel feet
(amplitude 65 mm +30/-35)

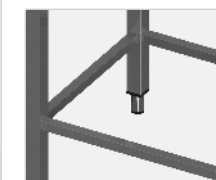

Welded frame
Legs made of stainless steel tube 40 x 40 mm
Frame made of stainless steel tube 40 x 20 and 25 x 25 mm



Hygienic type of welding

OPTIONAL FEATURES

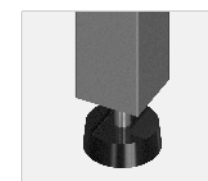

Heavy duty adjustable feet, 4 pcs.
(amplitude 40 mm, +20/-20)

Code: A-KS-M10x40
Price: 29 €

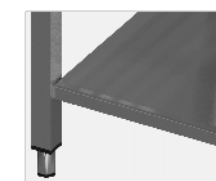

Removable shelves (2 pcs.)

Code: OG12-IRK-00.01
Price: 45 €

STANDARD FEATURES

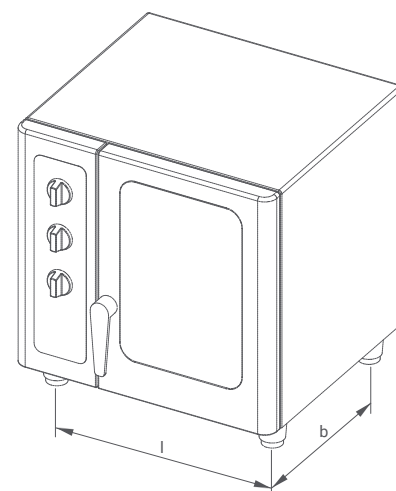
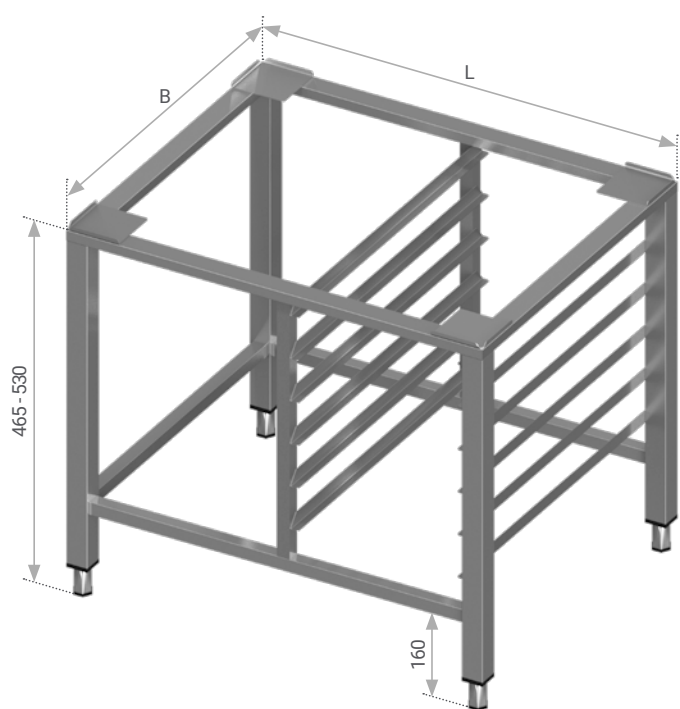

Recommended dimensions of stand:
 $L = l + 100 \text{ mm}$
 $B = b + 100 \text{ mm}$
l - distance between centre of front legs
b - distance between centre of side legs

Different dimensions and configurations are available on request. Examples on page 2.38.

Length L, mm	Width B, mm									
	550		600		700		800		900	
	Model	Price, €	Model	Price, €	Model	Price, €	Model	Price, €	Model	Price, €
500	OG6-PR1-50/55/50	253	OG6-PR1-50/60/50	261	OG6-PR1-50/70/50	278	OG6-PR1-60/80/50	297	OG6-PR1-50/90/50	316
600	OG6-PR1-60/55/50	263	OG6-PR1-60/60/50	271	OG6-PR1-60/70/50	288	OG6-PR1-60/80/50	307	OG6-PR1-60/90/50	326
700	OG6-PR1-70/55/50	273	OG6-PR1-70/60/50	281	OG6-PR1-70/70/50	298	OG6-PR1-70/80/50	317	OG6-PR1-70/90/50	336
800	OG6-PR1-80/55/50	283	OG6-PR1-80/60/50	291	OG6-PR1-80/70/50	308	OG6-PR1-80/80/50	327	OG6-PR1-80/90/50	346
900	OG6-PR1-90/55/50	293	OG6-PR1-90/60/50	301	OG6-PR1-90/70/50	318	OG6-PR1-90/80/50	337	OG6-PR1-90/90/50	356
1000	OG6-PR1-100/55/50	303	OG6-PR1-100/60/50	311	OG6-PR1-100/70/50	328	OG6-PR1-100/80/50	347	OG6-PR1-100/90/50	366



ANTI SLIDE CORNERS
(100 x 100 mm)



Adjustable stainless steel feet
(amplitude 65 mm +30/-35)

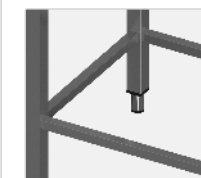

Welded frame
Legs made of stainless steel tube 40 x 40 mm
Frame made of stainless steel tube 40 x 20 and 25 x 25 mm



Hygienic type of welding

OPTIONAL FEATURES

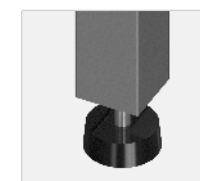

Heavy duty adjustable feet, 4 pcs.
(amplitude 40 mm, +20/-20)

Code: A-KS-M10x40
Price: 29 €

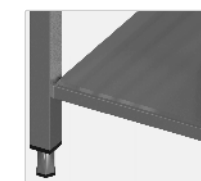

Removable shelves (2 pcs.)

Code: OG6-PR1-00.01
Price: 45 €

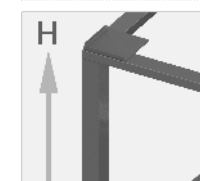

Customised stand height (600 - 900 mm)

Code: H=600; 700; 800; 900
Price: Free of charge

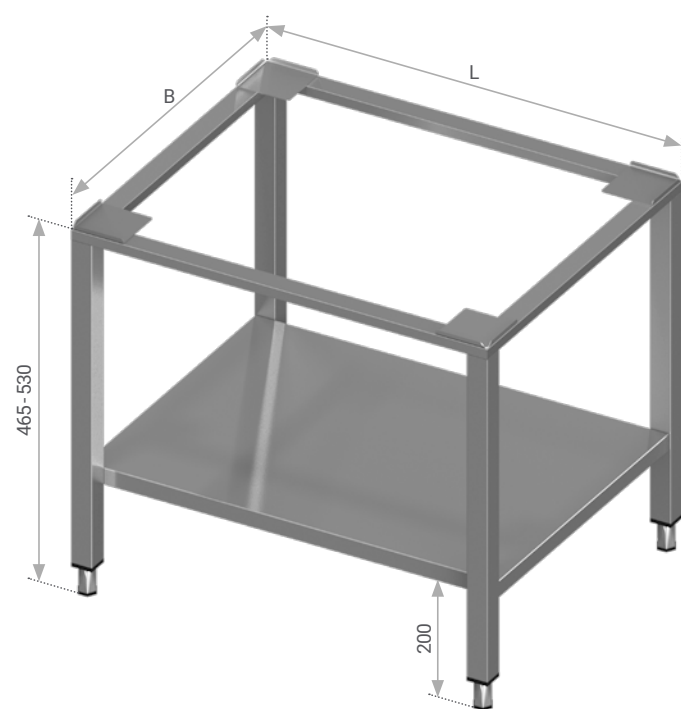

Information icon Different dimensions and configurations are available on request. Examples on page 2.38.

Length L, mm	Width B, mm							
	550		600		650		700	
	Model	Price, €	Model	Price, €	Model	Price, €	Model	Price, €
300	OX0-PL1-30/55/50	167	OX0-PL1-30/60/50	172	OX0-PL1-30/65/50	175	OX0-PL1-30/70/50	185
400	OX0-PL1-40/55/50	174	OX0-PL1-40/60/50	179	OX0-PL1-40/65/50	182	OX0-PL1-40/70/50	192
500	OX0-PL1-50/55/50	181	OX0-PL1-50/60/50	186	OX0-PL1-50/65/50	189	OX0-PL1-50/70/50	199
600	OX0-PL1-60/55/50	190	OX0-PL1-60/60/50	194	OX0-PL1-60/65/50	197	OX0-PL1-60/70/50	207
700	OX0-PL1-70/55/50	199	OX0-PL1-70/60/50	203	OX0-PL1-70/65/50	206	OX0-PL1-70/70/50	216
800	OX0-PL1-80/55/50	220	OX0-PL1-80/60/50	224	OX0-PL1-80/65/50	227	OX0-PL1-80/70/50	237
900	OX0-PL1-90/55/50	229	OX0-PL1-90/60/50	234	OX0-PL1-90/65/50	236	OX0-PL1-90/70/50	247
1000	OX0-PL1-100/55/50	238	OX0-PL1-100/60/50	243	OX0-PL1-100/65/50	245	OX0-PL1-100/70/50	256
1100	OX0-PL1-110/55/50	247	OX0-PL1-110/60/50	252	OX0-PL1-110/65/50	254	OX0-PL1-110/70/50	265
1200	OX0-PL1-120/55/50	256	OX0-PL1-120/60/50	261	OX0-PL1-120/65/50	263	OX0-PL1-120/70/50	274
1300	OX0-PL1-130/55/50	265	OX0-PL1-130/60/50	270	OX0-PL1-130/65/50	272	OX0-PL1-130/70/50	283
1400	OX0-PL1-140/55/50	274	OX0-PL1-140/60/50	279	OX0-PL1-140/65/50	281	OX0-PL1-140/70/50	292
1500	OX0-PL1-150/55/50	283	OX0-PL1-150/60/50	288	OX0-PL1-150/65/50	290	OX0-PL1-150/70/50	301

STANDARD FEATURES

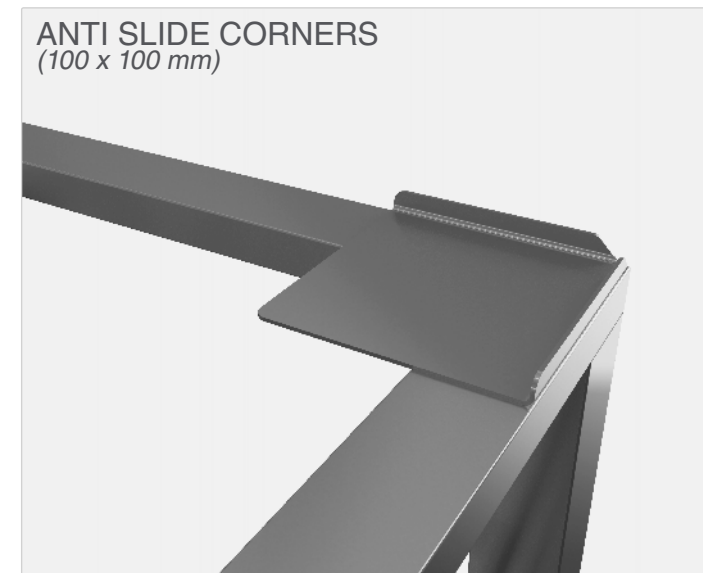

ANTI SLIDE CORNERS
(100 x 100 mm)



Adjustable stainless steel feet
(amplitude 65 mm +30/-35)

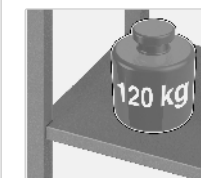

Welded frame
Legs made of stainless steel tube 40 x 40 mm
Max loading 120 kg/shelf (uniform layout)

OPTIONAL FEATURES

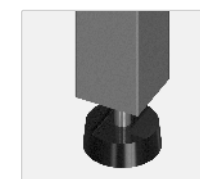

Heavy duty adjustable feet, 4 pcs.
(amplitude 40 mm, +20/-20)

Code: A-KS-M10x40
Price: 29 €

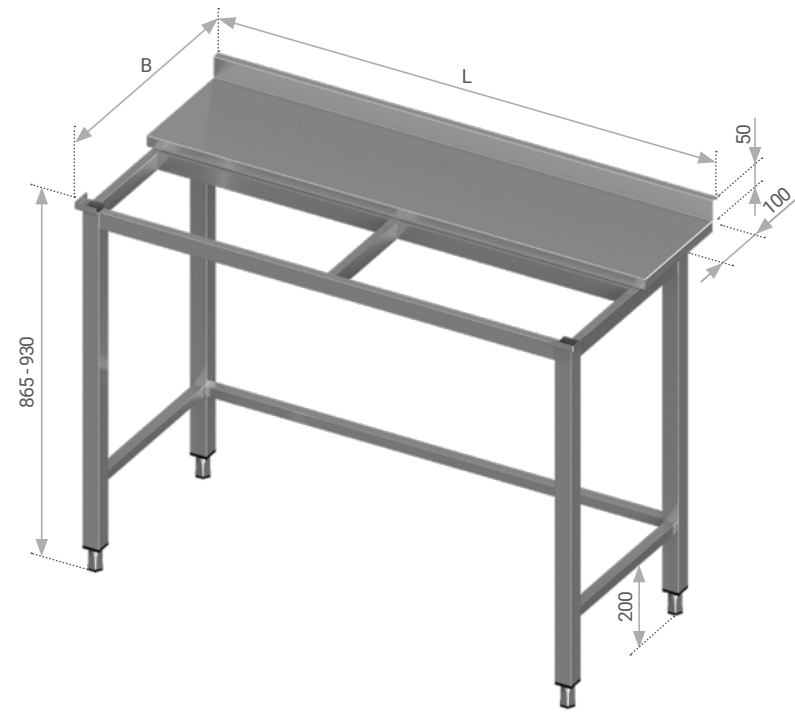

Information icon Different dimensions and configurations are available on request. Examples on page 2.38.

Length L, mm	Width B, mm			
	600		700	
	Model	Price, €	Model	Price, €
800	MP1-WRX-80/60/90	299	MP1-WRX-80/70/90	310
900	MP1-WRX-90/60/90	309	MP1-WRX-90/70/90	321
1000	MP1-WRX-100/60/90	319	MP1-WRX-100/70/90	333
1100	MP1-WRX-110/60/90	330	MP1-WRX-110/70/90	344
1200	MP1-WRX-120/60/90	340	MP1-WRX-120/70/90	355
1300	MP1-WRX-130/60/90	351	MP1-WRX-130/70/90	367
1400	MP1-WRX-140/60/90	362	MP1-WRX-140/70/90	378
1500	MP1-WRX-150/60/90	372	MP1-WRX-150/70/90	389
1600	MP1-WRX-160/60/90	382	MP1-WRX-160/70/90	401
1700	MP1-WRX-170/60/90	392	MP1-WRX-170/70/90	412
1800	MP1-WRX-180/60/90	403	MP1-WRX-180/70/90	423
1900	MP1-WRX-190/60/90	413	MP1-WRX-190/70/90	435
2000	MP1-WRX-200/60/90	424	MP1-WRX-200/70/90	446

STANDARD FEATURES



Adjustable stainless steel feet (amplitude 65 mm +30/-35)

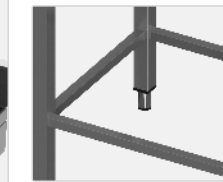

Welded frame
Legs made of stainless steel tube 40 x 40 mm
Frame made of stainless steel tube 40 x 20 and 25 x 25 mm

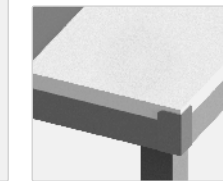

Designed for plastic boards 300 or 400 mm wide (plastic boards are not included)

OPTIONAL FEATURES

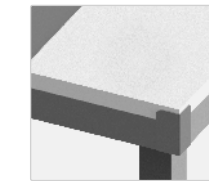

Plastic board: 20 mm thickness

Code: K-BPPL-2x30 (width 300 mm)
K-BPPL-2x40 (width 400 mm)
Price/m²: 212 €
Note: max length 2000 mm

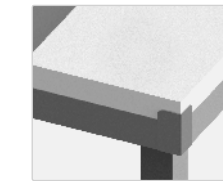

Plastic board: 30 mm thickness

Code: K-BPPL-3x30 (width 300 mm)
K-BPPL-3x40 (width 400 mm)
Price/m²: 328 €
Note: max length 2000 mm

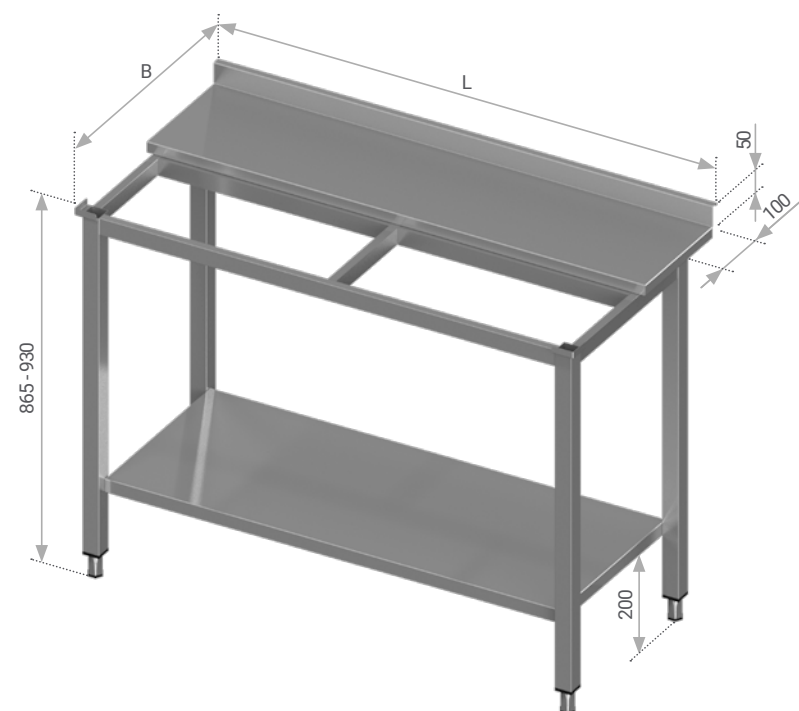

Information icon Different dimensions and configurations are available on request. Examples on page 2.38.

Length L, mm	Width B, mm			
	600		700	
	Model	Price, €	Model	Price, €
800	MP1-WLX-80/60/90	342	MP1-WLX-80/70/90	356
900	MP1-WLX-90/60/90	355	MP1-WLX-90/70/90	372
1000	MP1-WLX-100/60/90	369	MP1-WLX-100/70/90	386
1100	MP1-WLX-110/60/90	383	MP1-WLX-110/70/90	402
1200	MP1-WLX-120/60/90	397	MP1-WLX-120/70/90	416
1300	MP1-WLX-130/60/90	410	MP1-WLX-130/70/90	432
1400	MP1-WLX-140/60/90	423	MP1-WLX-140/70/90	446
1500	MP1-WLX-150/60/90	437	MP1-WLX-150/70/90	461
1600	MP1-WLX-160/60/90	450	MP1-WLX-160/70/90	476
1700	MP1-WLX-170/60/90	464	MP1-WLX-170/70/90	491
1800	MP1-WLX-180/60/90	478	MP1-WLX-180/70/90	506
1900	MP1-WLX-190/60/90	491	MP1-WLX-190/70/90	521
2000	MP1-WLX-200/60/90	505	MP1-WLX-200/70/90	536

STANDARD FEATURES

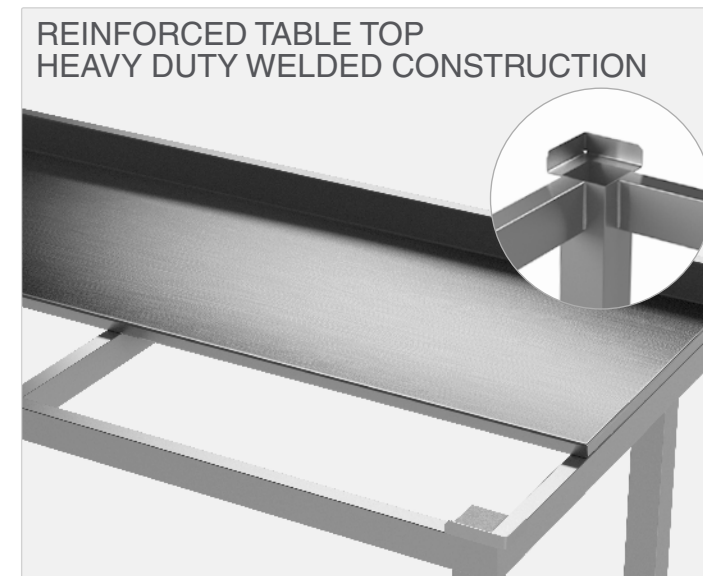

Adjustable stainless steel feet (amplitude 65 mm +30/-35)

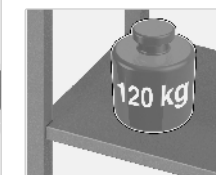

Welded frame
Legs made of stainless steel tube 40 x 40 mm
Max loading 120 kg/shelf (uniform layout)

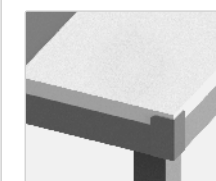

Designed for plastic boards 300 or 400 mm wide (plastic boards are not included)

OPTIONAL FEATURES

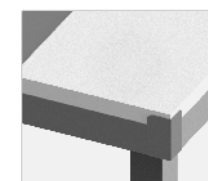

Plastic board: 20 mm thickness

Code: K-BPPL-2x30 (width 300 mm)
K-BPPL-2x40 (width 400 mm)
Price/m²: 212 €
Note: max length 2000 mm

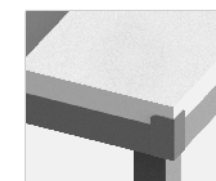

Plastic board: 30 mm thickness

Code: K-BPPL-3x30 (width 300 mm)
K-BPPL-3x40 (width 400 mm)
Price/m²: 328 €
Note: max length 2000 mm

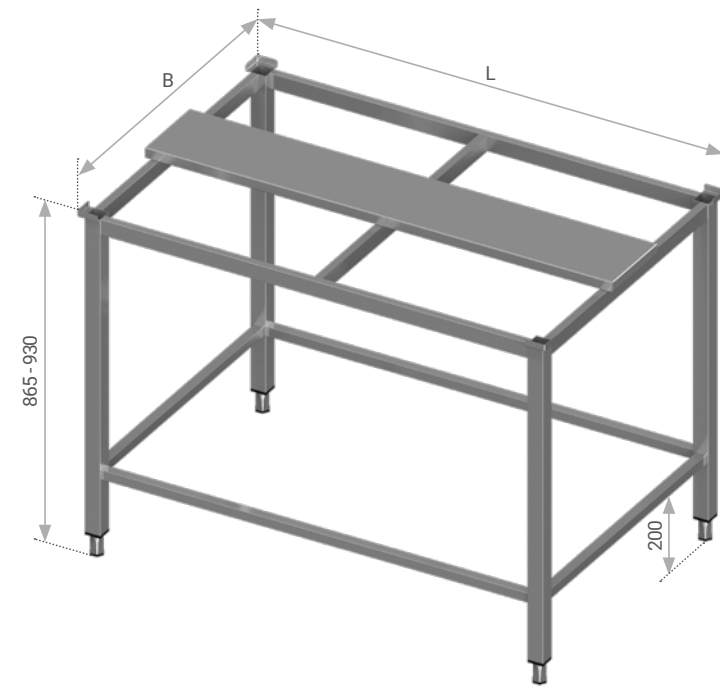

Information icon Different dimensions and configurations are available on request. Examples on page 2.38.

Length L, mm	Width B, mm							
	800		1200		1600		2000	
	Model	Price, €	Model	Price, €	Model	Price, €	Model	Price, €
1200	MP2-WRX-120/80/90	328	MP2-WRX-120/120/90	398	N/A	N/A	N/A	N/A
1300	MP2-WRX-130/80/90	338	MP2-WRX-130/120/90	412	N/A	N/A	N/A	N/A
1400	MP2-WRX-140/80/90	348	MP2-WRX-140/120/90	426	N/A	N/A	N/A	N/A
1500	MP2-WRX-150/80/90	358	MP2-WRX-150/120/90	441	N/A	N/A	N/A	N/A
1600	MP2-WRX-160/80/90	369	MP2-WRX-160/120/90	455	N/A	N/A	N/A	N/A
1700	MP2-WRX-170/80/90	379	MP2-WRX-170/120/90	470	N/A	N/A	N/A	N/A
1800	MP2-WRX-180/80/90	389	MP2-WRX-180/120/90	484	MP2-WRX-180/160/90	599	MP2-WRX-180/200/90	708
1900	MP2-WRX-190/80/90	400	MP2-WRX-190/120/90	499	MP2-WRX-190/160/90	614	MP2-WRX-190/200/90	725
2000	MP2-WRX-200/80/90	410	MP2-WRX-200/120/90	513	MP2-WRX-200/160/90	628	MP2-WRX-200/200/90	743

STANDARD FEATURES

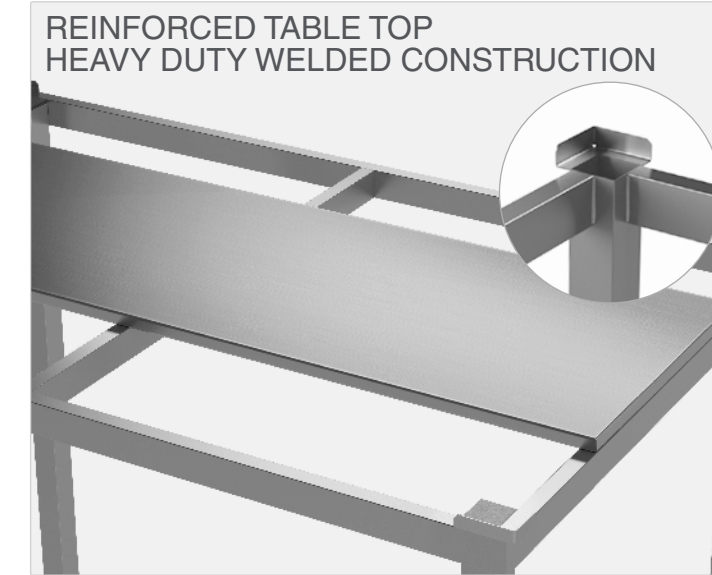

Adjustable stainless steel feet (amplitude 65 mm +30/-35)



Welded frame
Legs made of stainless steel tube 40 x 40 mm
Frame made of stainless steel tube 40 x 20 and 25 x 25 mm

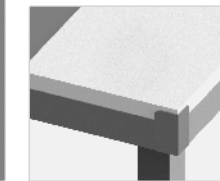

Designed for plastic boards 300 or 400 mm wide (plastic boards are not included)

OPTIONAL FEATURES

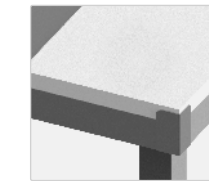

Plastic board: 20 mm thickness

Code: K-BPPL-2x30 (width 300 mm)
K-BPPL-2x40 (width 400 mm)

Price/m²: 212 €

Note: max length 2000 mm

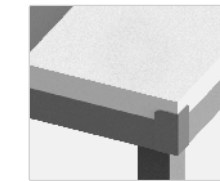

Plastic board: 30 mm thickness

Code: K-BPPL-3x30 (width 300 mm)
K-BPPL-3x40 (width 400 mm)

Price/m²: 328 €

Note: max length 2000 mm

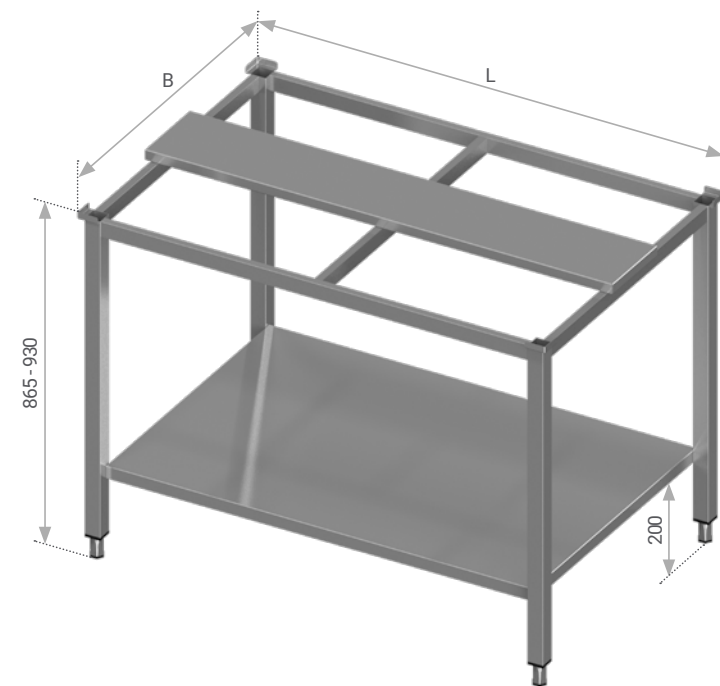

Information icon Different dimensions and configurations are available on request. Examples on page 2.38.

Length L, mm	Width B, mm							
	800		1200		1600		2000	
	Model	Price, €	Model	Price, €	Model	Price, €	Model	Price, €
1200	MP2-WLX-120/80/90	422	MP2-WLX-120/120/90	565	N/A	N/A	N/A	N/A
1300	MP2-WLX-130/80/90	439	MP2-WLX-130/120/90	588	N/A	N/A	N/A	N/A
1400	MP2-WLX-140/80/90	456	MP2-WLX-140/120/90	612	N/A	N/A	N/A	N/A
1500	MP2-WLX-150/80/90	474	MP2-WLX-150/120/90	636	N/A	N/A	N/A	N/A
1600	MP2-WLX-160/80/90	491	MP2-WLX-160/120/90	659	N/A	N/A	N/A	N/A
1700	MP2-WLX-170/80/90	509	MP2-WLX-170/120/90	683	N/A	N/A	N/A	N/A
1800	MP2-WLX-180/80/90	526	MP2-WLX-180/120/90	707	MP2-WLX-180/160/90	802	MP2-WLX-180/200/90	1024
1900	MP2-WLX-190/80/90	543	MP2-WLX-190/120/90	730	MP2-WLX-190/160/90	839	MP2-WLX-190/200/90	1068
2000	MP2-WLX-200/80/90	560	MP2-WLX-200/120/90	754	MP2-WLX-200/160/90	876	MP2-WLX-200/200/90	1113

STANDARD FEATURES

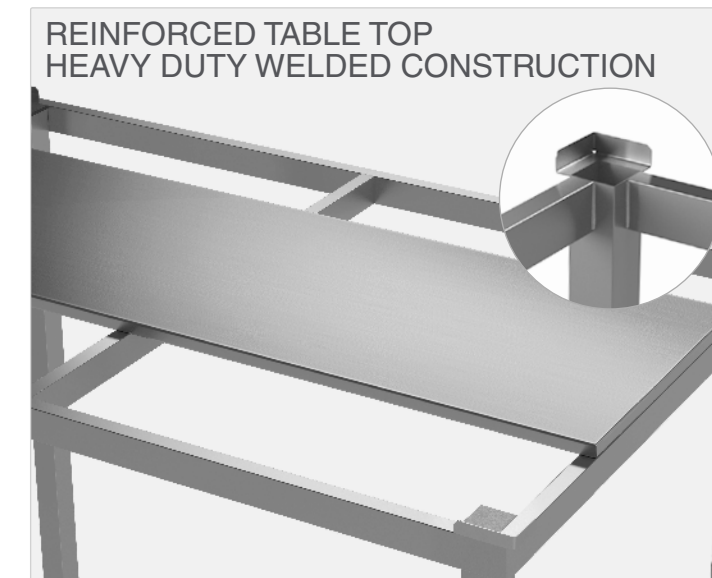

Adjustable stainless steel feet
(amplitude 65 mm +30/-35)

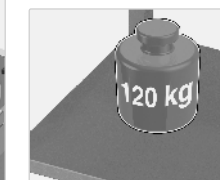

Welded frame
Legs made of stainless steel tube 40 x 40 mm
Max loading 120 kg/shelf (uniform layout)

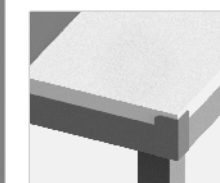

Designed for plastic boards 300 or 400 mm wide
(plastic boards are not included)

OPTIONAL FEATURES

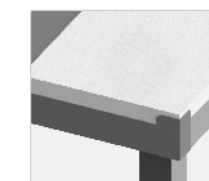

Plastic board: 20 mm thickness

Code: K-BPPL-2x30 (width 300 mm)
K-BPPL-2x40 (width 400 mm)

Price/m²: 212 €

Note: max length 2000 mm

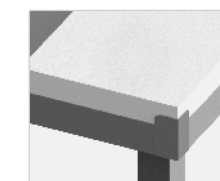

Plastic board: 30 mm thickness

Code: K-BPPL-3x30 (width 300 mm)
K-BPPL-3x40 (width 400 mm)

Price/m²: 328 €

Note: max length 2000 mm

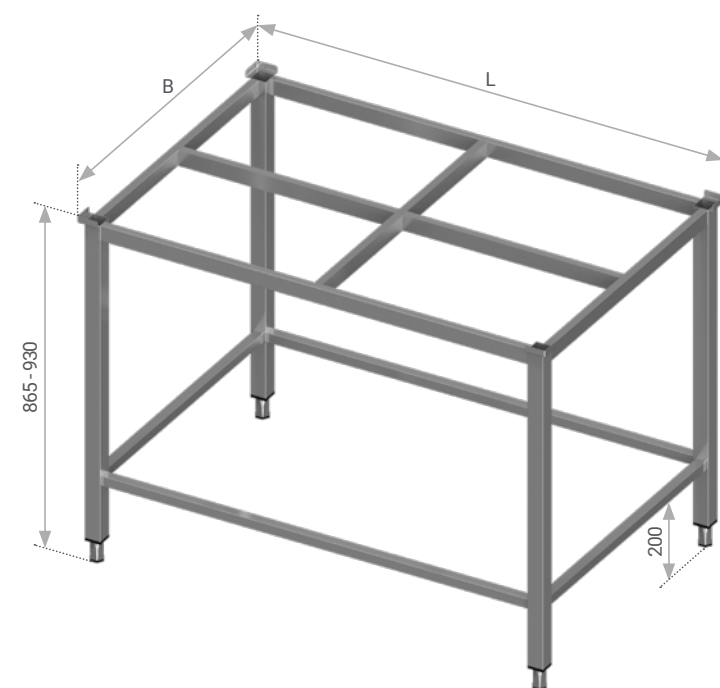

*More accessories on page 2.32.
Different dimensions and configurations are available on request. Examples on page 2.38.*

Length L, mm	Width B, mm							
	700		800		900		1000	
	Model	Price, €	Model	Price, €	Model	Price, €	Model	Price, €
1200	MP3-WRX-120/70/90	277	MP3-WRX-120/80/90	281	MP3-WRX-120/90/90	286	MP3-WRX-120/100/90	291
1300	MP3-WRX-130/70/90	282	MP3-WRX-130/80/90	287	MP3-WRX-130/90/90	291	MP3-WRX-130/100/90	297
1400	MP3-WRX-140/70/90	287	MP3-WRX-140/80/90	293	MP3-WRX-140/90/90	297	MP3-WRX-140/100/90	302
1500	MP3-WRX-150/70/90	293	MP3-WRX-150/80/90	298	MP3-WRX-150/90/90	302	MP3-WRX-150/100/90	307
1600	MP3-WRX-160/70/90	298	MP3-WRX-160/80/90	303	MP3-WRX-160/90/90	308	MP3-WRX-160/100/90	312
1700	MP3-WRX-170/70/90	303	MP3-WRX-170/80/90	308	MP3-WRX-170/90/90	313	MP3-WRX-170/100/90	317
1800	MP3-WRX-180/70/90	309	MP3-WRX-180/80/90	313	MP3-WRX-180/90/90	318	MP3-WRX-180/100/90	323
1900	MP3-WRX-190/70/90	314	MP3-WRX-190/80/90	318	MP3-WRX-190/90/90	323	MP3-WRX-190/100/90	329
2000	MP3-WRX-200/70/90	319	MP3-WRX-200/80/90	324	MP3-WRX-200/90/90	329	MP3-WRX-200/100/90	334

STANDARD FEATURES

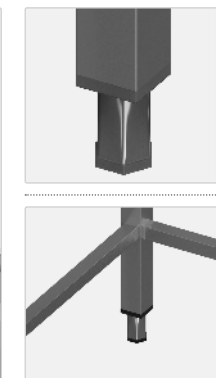
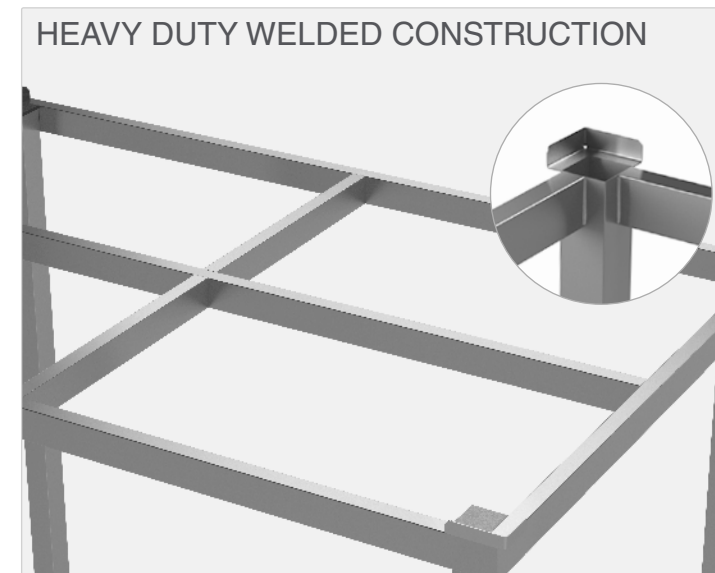

Adjustable stainless steel feet
(amplitude 65 mm +30/-35)



Welded frame
Legs made of stainless steel tube 40 x 40 mm
Frame made of stainless steel tube 40 x 20 and 25 x 25 mm

OPTIONAL FEATURES

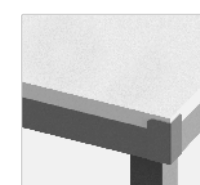

Plastic table top: 20 mm thickness

Code: K-BPPL-2
Price/m²: 212 €
Note: max length 2000 mm

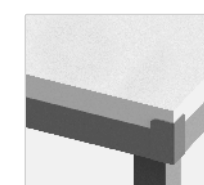

Plastic table top: 30 mm thickness

Code: K-BPPL-3
Price/m²: 328 €
Note: max length 2000 mm



Solid ash table top: 40 mm thickness

Code: A-DSM-U
Price/m²: 237 €
Note: max length 2000 mm

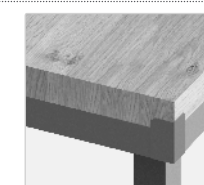

Solid beech table top: 40 mm thickness

Code: A-DSM-B
Price/m²: 385 €
Note: max length 2000 mm



Solid oak table top: 40 mm thickness

Code: A-DSM-A
Price/m²: 315 €
Note: max length 2000 mm

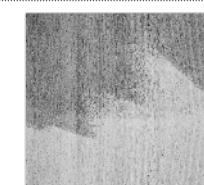

Oil finish on both sides (3 layers)

Code: A-DSM-OIL
Price/m²: 70 €



Marble table top: 30 mm thickness

Code: A-DSA-CARRARA
Price/m²: Ask for price
Note: max length 2000 mm

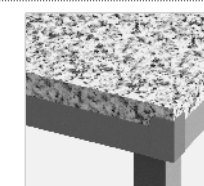

Granite table top: 30 mm thickness

Code: A-DSA-G681
Price/m²: Ask for price
Note: max length 2000 mm

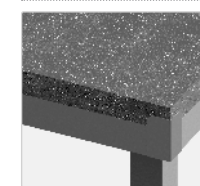

Granite table top: 30 mm thickness

Code: A-DSA-GALAXY
Price/m²: Ask for price
Note: max length 2000 mm

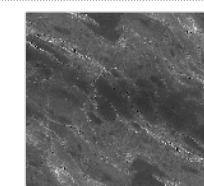

Non standard stone table top

Code: Z-STONE
Price/m²: Ask for price
Note: max length 2000 mm

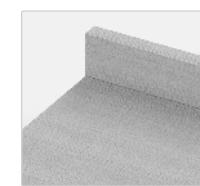

Upstand (height 50 mm)

All options on page 2.32

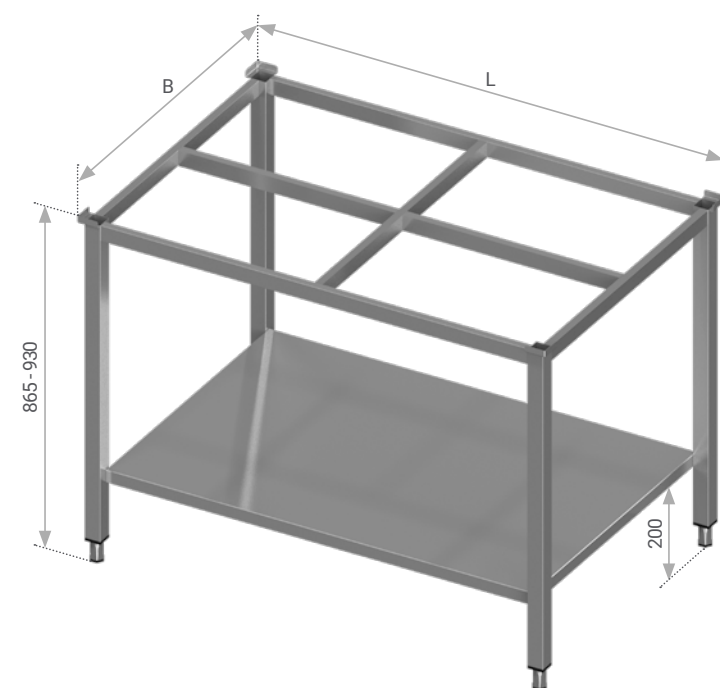

*More accessories on page 2.32.
Different dimensions and configurations are available on request. Examples on page 2.38.*

Length L, mm	Width B, mm							
	700		800		900		1000	
	Model	Price, €	Model	Price, €	Model	Price, €	Model	Price, €
1200	MP3-WLX-120/70/90	343	MP3-WLX-120/80/90	352	MP3-WLX-120/90/90	371	MP3-WLX-120/100/90	380
1300	MP3-WLX-130/70/90	352	MP3-WLX-130/80/90	363	MP3-WLX-130/90/90	382	MP3-WLX-130/100/90	392
1400	MP3-WLX-140/70/90	362	MP3-WLX-140/80/90	373	MP3-WLX-140/90/90	394	MP3-WLX-140/100/90	405
1500	MP3-WLX-150/70/90	372	MP3-WLX-150/80/90	383	MP3-WLX-150/90/90	406	MP3-WLX-150/100/90	417
1600	MP3-WLX-160/70/90	381	MP3-WLX-160/80/90	393	MP3-WLX-160/90/90	417	MP3-WLX-160/100/90	430
1700	MP3-WLX-170/70/90	391	MP3-WLX-170/80/90	404	MP3-WLX-170/90/90	430	MP3-WLX-170/100/90	442
1800	MP3-WLX-180/70/90	401	MP3-WLX-180/80/90	414	MP3-WLX-180/90/90	441	MP3-WLX-180/100/90	454
1900	MP3-WLX-190/70/90	411	MP3-WLX-190/80/90	424	MP3-WLX-190/90/90	452	MP3-WLX-190/100/90	467
2000	MP3-WLX-200/70/90	421	MP3-WLX-200/80/90	435	MP3-WLX-200/90/90	465	MP3-WLX-200/100/90	479

STANDARD FEATURES

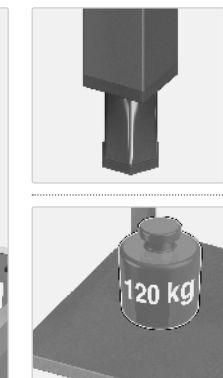
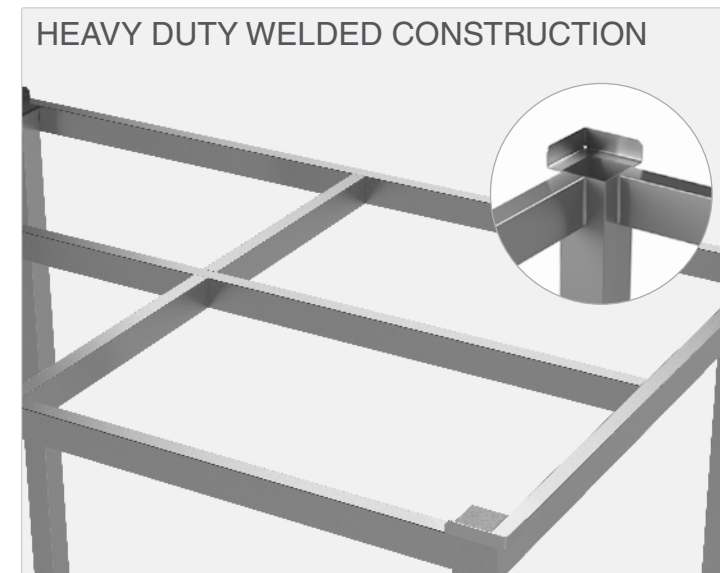

Adjustable stainless steel feet
(amplitude 65 mm +30/-35)

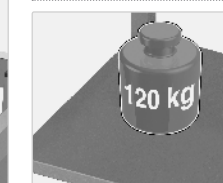

Welded frame
Legs made of stainless steel tube 40 x 40 mm
Max loading 120 kg/shelf (uniform layout)

OPTIONAL FEATURES

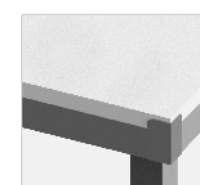

Plastic table top: 20 mm thickness

Code: K-BPPL-2
Price/m²: 212 €
Note: max length 2000 mm

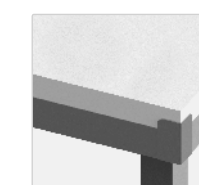

Plastic table top: 30 mm thickness

Code: K-BPPL-3
Price/m²: 328 €
Note: max length 2000 mm



Solid ash table top: 40 mm thickness

Code: A-DSM-U
Price/m²: 237 €
Note: max length 2000 mm



Solid beech table top: 40 mm thickness

Code: A-DSM-B
Price/m²: 385 €
Note: max length 2000 mm



Solid oak table top: 40 mm thickness

Code: A-DSM-A
Price/m²: 315 €
Note: max length 2000 mm



Oil finish on both sides (3 layers)

Code: A-DSM-OIL
Price/m²: 70 €



Marble table top: 30 mm thickness

Code: A-DSA-CARRARA
Price/m²: Ask for price
Note: max length 2000 mm

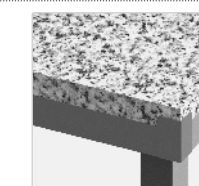

Granite table top: 30 mm thickness

Code: A-DSA-G681
Price/m²: Ask for price
Note: max length 2000 mm

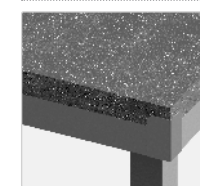

Granite table top: 30 mm thickness

Code: A-DSA-GALAXY
Price/m²: Ask for price
Note: max length 2000 mm

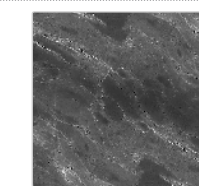

Non standard stone table top

Code: Z-STONE
Price/m²: Ask for price
Note: max length 2000 mm

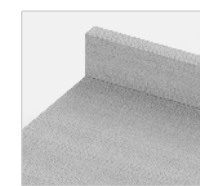

Upstand (height 50 mm)

All options on page 2.32

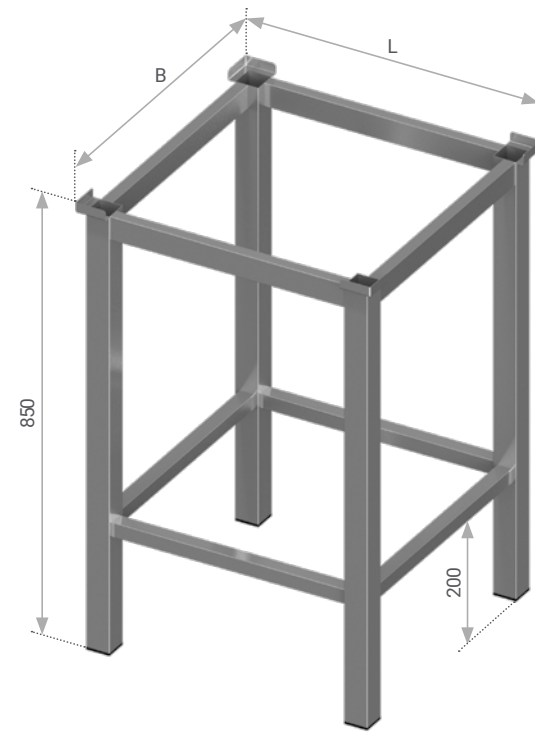

Information icon Different dimensions and configurations are available on request. Examples on page 2.38.

Width B, mm			
500		600	
Model	Price, €	Model	Price, €
MK3-WRX-50/50/85	176	MK3-WRX-80/60/85	192

STANDARD FEATURES

HEAVY DUTY WELDED CONSTRUCTION

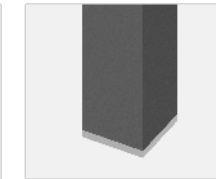
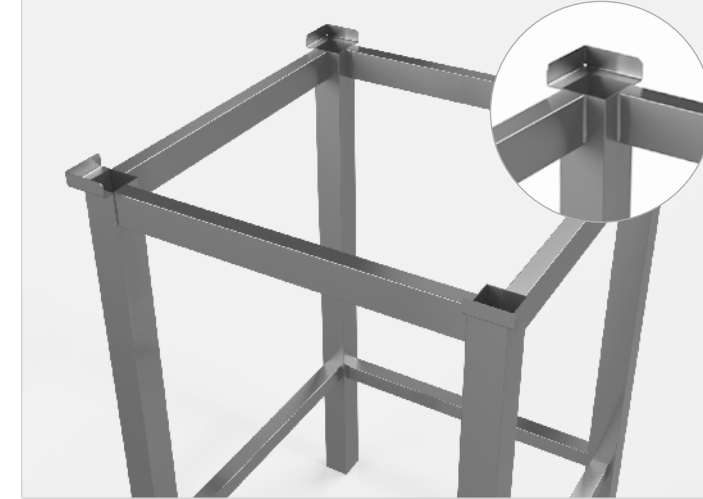

Heavy duty shock absorbing plastic feet

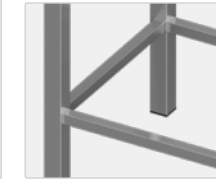

Welded frame
Legs made of stainless steel tube 40 x 40 mm,
Frame made of stainless steel tube 40 x 20
and 25 x 25 mm

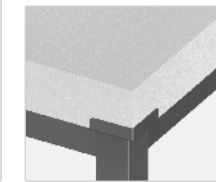

Designed for chopping block

OPTIONAL FEATURES

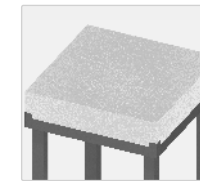

Plastic chopping block: 500 x 500 x 100 mm

Code: K-BPK-50x50x10
Price: 290 €

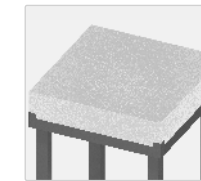

Plastic chopping block: 800 x 600 x 100 mm

Code: K-BPK-80x60x10
Price: 483 €

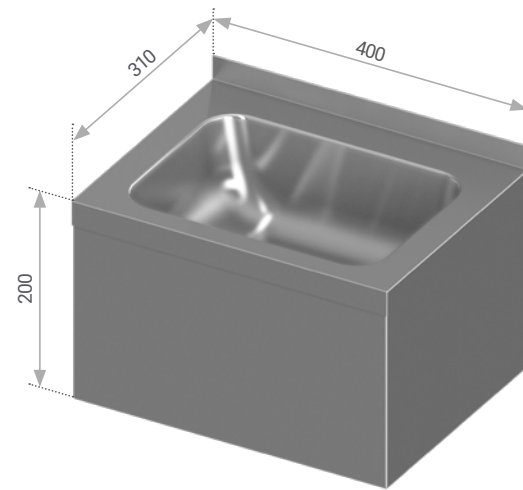

- With rear upstand (height 30 mm)
- Sink dimensions 325 x 230 x 130 mm
- Profile for fixing to the wall included

Length L, mm	Width B, mm		Price, €
	Model	310	
400	RZZ-40/31/25		164

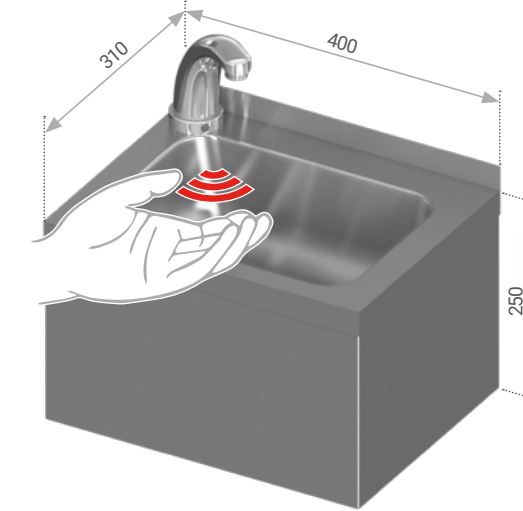

- With rear upstand (height 30 mm)
- Sink dimensions 325 x 230 x 130 mm
- Profile for fixing to the wall included
- Sensor operated mixer (reacts on hands at 0.1 m distance from sensor)
- Connection to cold and hot water supply
- Mechanical temperature and flow rate adjustment
- Battery 2CR5 6V included

Length L, mm	Width B, mm		Price, €
	Model	310	
400	RSZ-40/31/25		508

HANDBASIN WITH HIGH UPSTAND

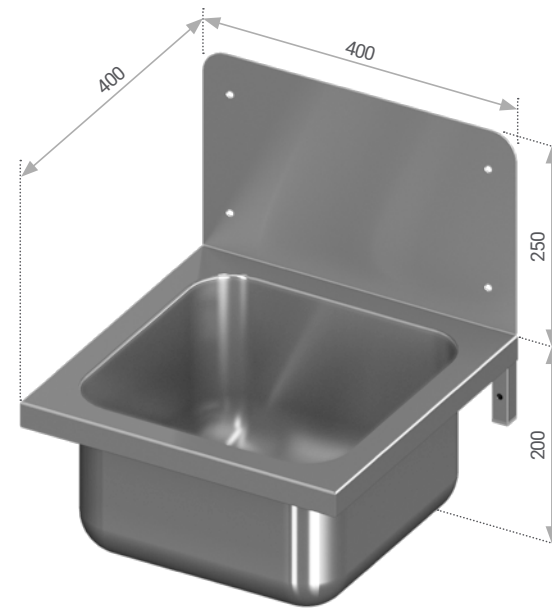

- With rear upstand (height 250 mm)
- Sink dimensions 330 x 330 x 200 mm

Length L, mm	Width B, mm		Price, €
	Model	400	
400	RZA-40/40/20		237

HANDBASIN WITH KNEE OPERATED MIXER

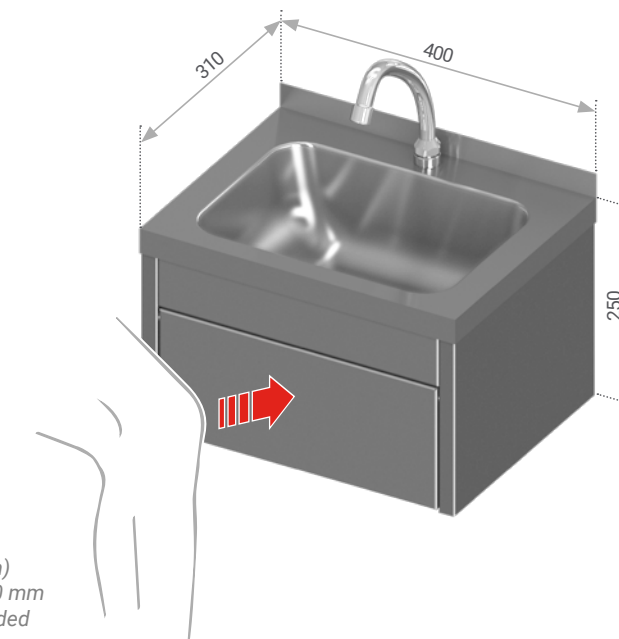

- With rear upstand (height 30 mm)
- Sink dimensions 325 x 230 x 130 mm
- Profile for fixing to the wall included
- Knee operated mixer
- Connection to cold or pre-mixed water supply

Length L, mm	Width B, mm		Price, €
	Model	310	
400	RKZ-40/31/25		241

UPSTANDS

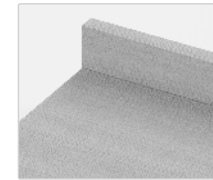

Wood upstand (height 50 mm)
 Code: A-DSBM-2
 Price/m: 22 €

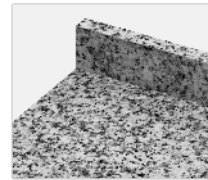

Stone upstand (height 50 mm)
 Code: A-DSBM-2
 Price/m: Ask for price

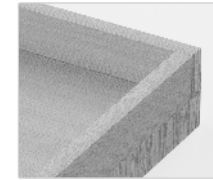

Wood upstand on rear and both sides (height 50 mm)
 Code: A-DSBM-6
 Price/m: 30 €

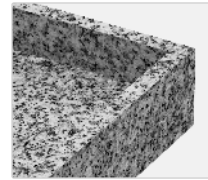

Stone upstand on rear and both sides (height 50 mm)
 Code: A-DSBM-6
 Price/m: Ask for price

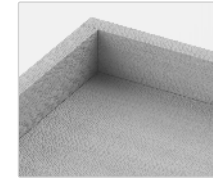

Wood upstand on rear and side (height 50 mm)
 Code: A-DSBM-4 (left)
 A-DSBM-5 (right)
 Price/m: 26 €

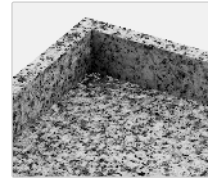

Stone upstand on rear and side (height 50 mm)
 Code: A-DSBM-4 (left)
 A-DSBM-5 (right)
 Price/m: Ask for price

i NOVAMETA STANDARD TERMS

Applicability

These Standard Terms ("Terms") apply to all products supplied directly by Novameta to its distributors.

Validity of quotations

Quotations are valid for 90 days unless otherwise explicitly stated in the individual quotation. Not responsible for misprints.

Delivery terms

Provided in the proforma invoice.

In case of ex-works (INCOTERMS 2010) Novameta shall not be liable for delays and the distributor shall not be permitted to terminate the purchase due to delays unless agreed to in writing.

Payment terms

Provided in the proforma invoice.

If a higher credit limit is necessary, security is mandatory. Novameta may reduce a credit limit at any time if considered appropriate by Novameta.

Storage terms

Provided in the proforma invoice.

Retention of Title

Novameta shall retain title in all products and components sold to the distributor until the distributor has paid for the products in full (including transportation and packaging costs).

Warranty terms

Novameta provides a Manufacturer's warranty for all of the equipment against defects in materials and workmanship for a period of 1 year from the date of invoicing of the defective product or component to the distributor. Manufacturer undertakes to replace all inferior parts to proper quality parts or materials. In case of a fault, a properly filled claim is required and must contain all essential information relative to the fault. Faulty parts shall be returned to Manufacturer for further inspection.

Extended warranty

The extended warranty is solely applicable to certain equipment (indicated in the price list). The extended warranty costs extra of the item's list price. Standard warranty terms apply.

Warranty exclusions and limitations of liability

The warranty in these Terms shall be the distributor's exclusive remedy for defective products and components towards Novameta. Novameta shall not be liable for any costs, expenses, losses or claims (whether direct, indirect, consequential or otherwise) relating to defective products or components unless otherwise explicitly stated herein or agreed in writing. Any expenses in connection with the installation or costs of making adjustments (including service procedures, travel time costs) on the equipment to comply with the supply at the point of installation are not covered by this warranty.

The producer does not take any responsibility for damages that occur due to ignorance of cautions, improper maintenance or mechanical damages of the unit, including those, caused during the delivery. This warranty is not effective if damage occurs from improper installation, misuse; incorrect voltage supply, wear and tear from normal usage, accidental breakage, damage or if the equipment is operated contrary to the user instructions. The warranty does not cover if the damage occurs due to natural disasters; fire, if repair service was made by unauthorized person.

In case of a failure not covered by the warranty, we provide a possibility to purchase spare parts.

i NOVAMETA STANDARD TERMS

Procedure for repair or replacement under the warranty

The distributor shall, at its own costs, make all reasonable attempts to repair any defective component or product.

If such repair is not possible for the distributor, the distributor shall contact Novameta in writing immediately (within 3 working days) upon suspicion of any defects that may be covered by the warranty. If Novameta is not contacted immediately (within 3 working days) in such cases, the distributor shall have no remedies.

Distributor's contact shall include specific information as to the suspected defect the relevant order number and a copy of the relevant invoice.

After timely receipt of the above, Novameta will decide if there is a defect, whether the claim is covered by the warranty, and whether the product or component is to be replaced.

In cases where Novameta decides to replace defective products or components with new ones, the distributor will be billed the full amount for the goods when they are sent. This amount will then be credited when the defective product or components is returned to Novameta and it is established that the defective product or component is covered by the warranty.

With regard to the transport of products and components, Novameta will pay the freight of new or repaired products and components, while the distributor will pay the freight for defective goods that are returned (and any other costs related to the return of the goods). The warranty does not cover expenses of the service procedures performed. Novameta does not provide service.

Unless otherwise agreed in writing, the defective product or component should always be returned to Novameta: Draugystės g. 15D, LT-51227 Kaunas, Lithuania.

Cancellations

If an order cancellation request is made after confirmation of drawing and proforma invoice, adjustments are not possible and production cannot be stopped. In case of cancellation product will be charged in full.

Shipping and packing

Novameta will pack products for shipment in Novameta standard packaging. If the distributor has other requirements as to packing, the distributor shall contact Novameta to make special arrangements.

Delivery recommendations

Upon receipt, inspect units immediately for any shipping damage and notify carrier immediately if damage is found. It must be reported immediately (upon delivery) in writing in the CMR. Otherwise neither the Manufacturer nor the carrier can take responsibility for transport damage. All items are thoroughly inspected and carefully packed before leaving our factory, thus Novameta cannot accept responsibility for any shipping damage, however Novameta will assist in filing a claim.

Liability and Product liability

Novameta shall only be liable for defects and product liability to the extent set out herein (see particularly warranty terms). In addition to the aforesaid all liability is capped at the invoiced price of the defective product. All other liability is hereby excluded.

Choice of law and Venue

These Terms and the cooperation between Novameta and its distributors, including any disputes relating thereto, shall be governed by Lithuanian law.

Any disputes shall be settled before the Lithuanian courts, which shall have exclusive jurisdiction.

Company No. 235886490, VAT Reg. No. LT 358864917

Reg. No. 048959, Centre of Registers

IBAN: LT227300010071982293, Swedbank, AB

REFERENCES

COMPANY CANTEENS

- Booking.com Headquarters*
Amsterdam, Netherlands
- Novo Nordisk Pharmaceutical Company*
Bagsvaerd, Denmark
- Google Office*
Copenhagen, Denmark
- Michael Kors Distribution Centre*
Venlo, Netherlands
- Samsung Electronics Benelux Office*
Amsterdam, Netherlands
- Nordea Bank Headquarters*
Oslo, Norway
- ING Bank Office*
Amsterdam, Netherlands
- Rabobank Bank*
Eindhoven, Netherlands
- KLM Catering Services Office*
Amsterdam, Netherlands



ZE16-1254



ZE16-2001



ZL14-1157



ZQ16-1125

EDUCATIONAL INSTITUTIONS

- University of Wolverhampton*
Wolverhampton, United Kingdom
- Copenhagen International School*
Copenhagen, Denmark
- Farmen Barnehage Kindergarten*
Levanger, Norway



ZA16-2031

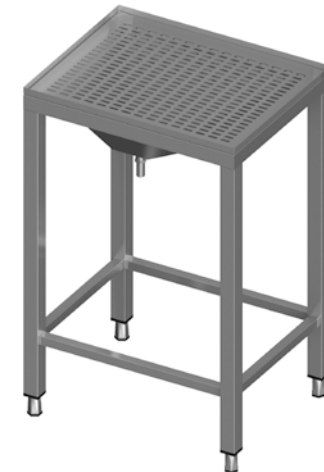

ZI15-2007

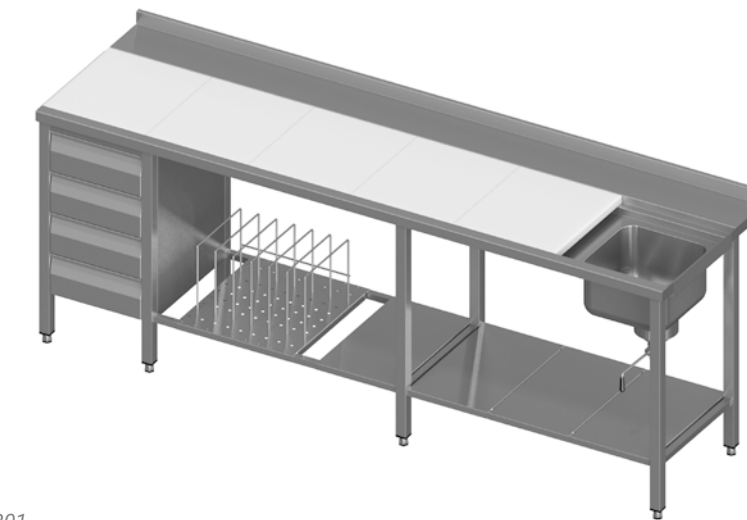

ZD13-1201

HOTELS

- Ramada Resort Hadera Beach Hotel*
Hadera, Israel
- Hilton Slussen Hotel*
Stockholm, Sweden
- Kempinski Hotel Cathedral Square*
Vilnius, Lithuania
- Thon Hotel Chain*
Norway
- Tallink City Hotel*
Tallinn, Estonia



ZB16-2004

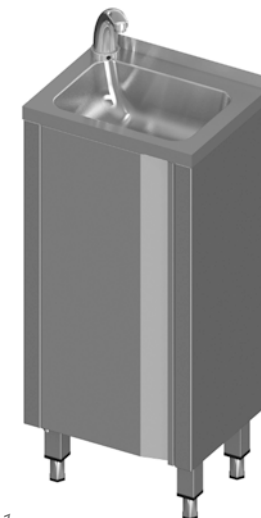

ZE16-2011

LEISURE AND LARGE VENUES

- Royal Theatre Carre*
Amsterdam, Netherlands
- LEGOLAND Amusement Park*
Billund, Denmark
- The Well Spa Centre*
Oslo, Norway

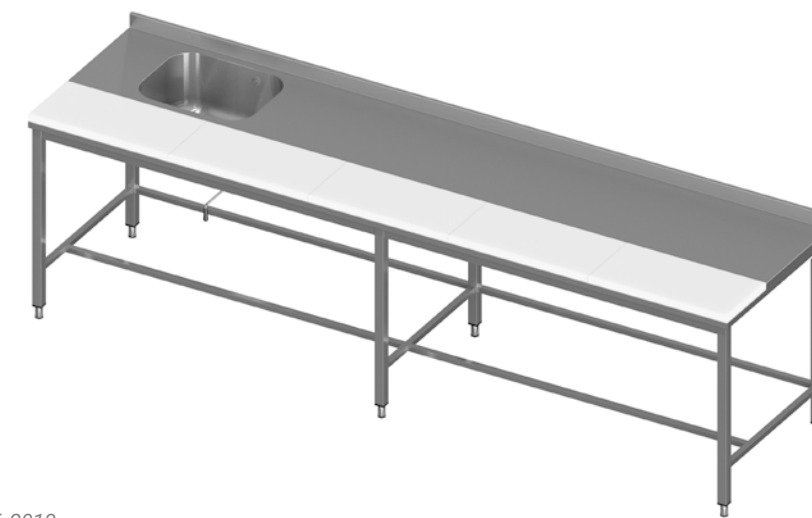

ZA16-2013

REFERENCES

RESTAURANTS AND BARS

- TGI Fridays Bar & Restaurant*
Sweden
- Chateau Motel Nightclub*
Copenhagen, Denmark
- Happy Italy Restaurants*
Netherlands
- Milu Bar & Restaurant*
The Hague, Netherlands
- Easy Wine Bar*
Riga, Latvia
- Flammen Restaurants*
Denmark
- Bierhuis Restaurant*
Uppsala, Sweden
- Hotcha Restaurant*
Liverpool, United Kingdom

GOVERNMENT & PUBLIC SERVICES

- Ministry of Economic Affairs*
The Hague, Netherlands
- Embassy of Hungary*
Stockholm, Sweden
- Statsfængslet Nordfalster Prison*
Nordfalster, Denmark

HEALTHCARE

- Mare Klinikum Medical Diagnostic Centre*
Kiel, Germany
- Wexham Park Hospital*
Slough, United Kingdom
- Zaans Medical Centre*
Zaandam, Netherlands
- Rikshospitalet Hospital*
Oslo, Norway
- Syrenparken Psychiatric Hospital*
Børkop, Denmark

SHOPS AND SUPERMARKETS

- ICA Supermarkets*
Sweden
- IKEA Stores*
Netherlands, Lithuania
- Coop Supermarkets*
Norway
- Hema Supermarkets*
Netherlands

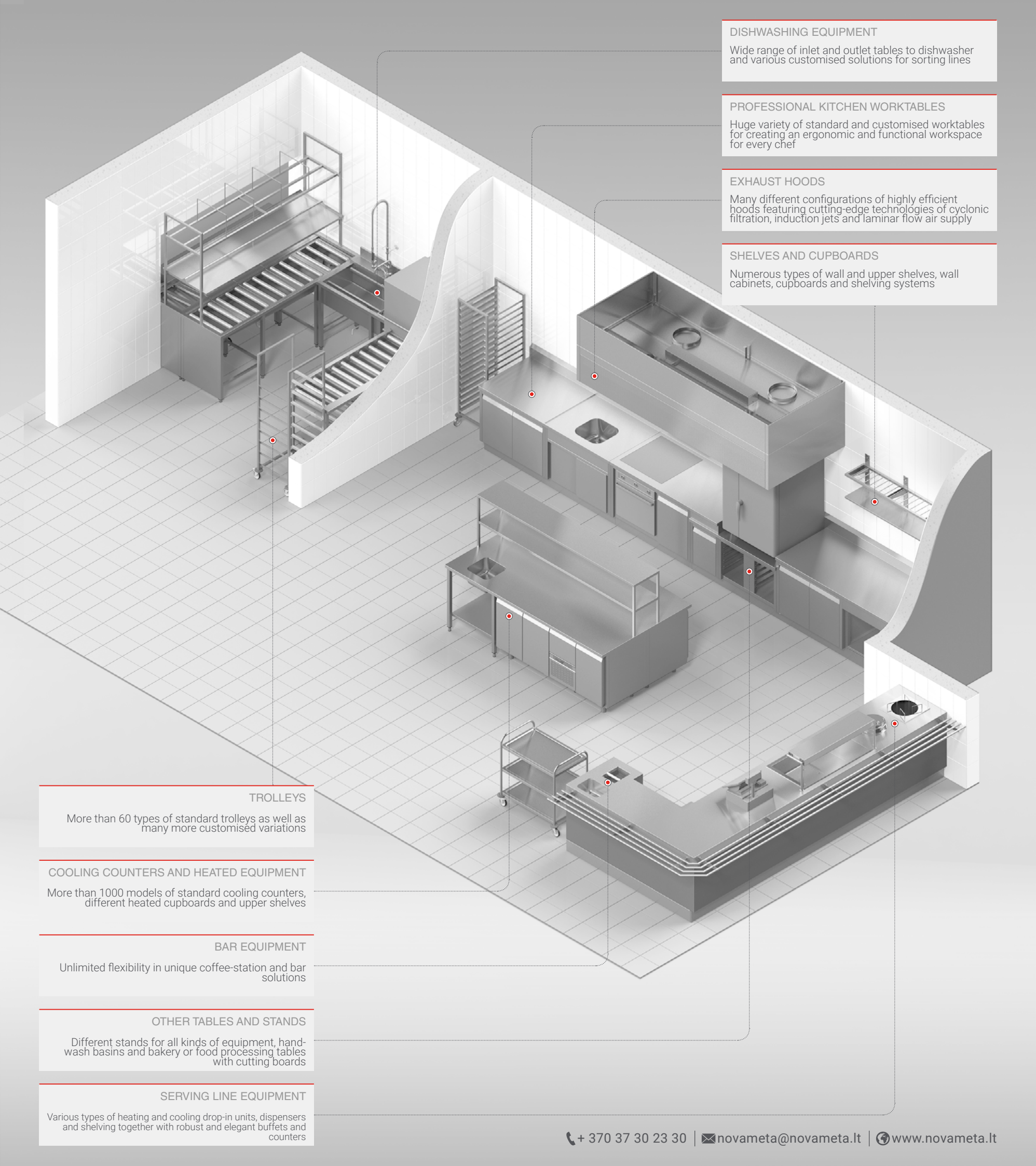

DISHWASHING EQUIPMENT

Wide range of inlet and outlet tables to dishwasher and various customised solutions for sorting lines

PROFESSIONAL KITCHEN WORKTABLES

Huge variety of standard and customised worktables for creating an ergonomic and functional workspace for every chef

EXHAUST HOODS

Many different configurations of highly efficient hoods featuring cutting-edge technologies of cyclonic filtration, induction jets and laminar flow air supply

SHELVES AND CUPBOARDS

Numerous types of wall and upper shelves, wall cabinets, cupboards and shelving systems

TROLLEYS

More than 60 types of standard trolleys as well as many more customised variations

COOLING COUNTERS AND HEATED EQUIPMENT

More than 1000 models of standard cooling counters, different heated cupboards and upper shelves

BAR EQUIPMENT

Unlimited flexibility in unique coffee-station and bar solutions

OTHER TABLES AND STANDS

Different stands for all kinds of equipment, hand-wash basins and bakery or food processing tables with cutting boards

SERVING LINE EQUIPMENT

Various types of heating and cooling drop-in units, dispensers and shelving together with robust and elegant buffets and counters